



Evaluation of quenching process on low cycle fatigue life for cylinder head

Hojjat Ashouri

Department of Mechanical Engineering, Varamin-Pishva Branch, Islamic Azad University, Varamin, Iran

ARTICLE INFO

Article history:

Received : 28 Jul 2022

Accepted: 25 Sep 2022

Published: 18 Oct 2022

Keywords:

Low cycle fatigue life

Finite element analysis

Engines cylinder heads

Quenching process

ABSTRACT

Due to the complex geometry and thermos-mechanical loading, cylinder heads are the most challenging parts among all parts engines. They must endure cyclic thermal and mechanical loading throughout their lifetime. Cast aluminum alloys are normally quenched after solution treatment process to increase mechanical properties which can create high residual stress. Residual stress is one of the dominant elements for failure of cylinder heads. The impact of residual stress on the thermal stress and low cycle fatigue life (LCF) of cylinder heads was studied. For this goal, Solidworks software was used to model the cylinder heads. Then the thermo-mechanical analysis was performed to determine the temperature and stress field in ANSYS software. Finally, the fatigue life analysis that considers residual stress effect was done. The thermo-mechanical analysis showed that the maximum temperature and stress happen in the valves bridge between the two exhaust valves. The results of finite element analysis (FEA) proved that the impact of residual stress in LCF is considerable. Thus, residual stress must be investigated in the thermo-mechanical fatigue analysis of the cylinder heads.

1. Introduction

One of the important issues of engines is cylinder head fatigue cracks at valve bridge area. With the rising demand for output capacity, fuel consumption, thermal efficiency, combustion temperature and fatigue life make cylinder head to be the most serious and complex component for vehicle design [1-4]. The cylinder heads withstand two type of the fatigue loading. The combustion pressure creates mechanical loads, which relates to high cycle fatigue (HCF) behavior of the cylinder head. The engine on and off, begets thermal loads, which relate to the low cycle fatigue behavior of the cylinder head [1, 4, 5, 6, 7]. According to these combined thermo-mechanical fatigue (TMF), the cylinder head

material must have some properties such as sufficient mechanical strength at high temperature to tolerate failure and fatigue cracking. TMF may causes to fatigue cracks and failure in cylinder head is the limiting element in the conception of new engine design [2,35,8].

Cast aluminum alloys, such as A356, are widely used in engine cylinder heads to decrease the weight of engine and improving fuel consumption [2, 3, 5, 6, 9, 10]. These parts are often heat treated to increase material mechanical properties. Heat treatment consist of solution treatment, quench and ageing. Residual stresses can happen in casting and quenching steps of the manufacturing processes. Residual stress in the casting step is created by material shrinkage

*Corresponding Author

Email Address: ashori1394@gmail.com

<https://doi.org/10.22068/ase.2022.613>

Evaluation of quenching process on low cycle fatigue life for cylinder head

during solidification and the temperature gradient [9, 10, 11, 12]. Residual stresses are one of the dominant factors affecting fatigue life of important cast components such as cylinder head. Thus, assessing of residual stress and detection a method to decrease it is necessary to increase the quality and reliability of cylinder heads [13, 14, 15].

In the literature, previous researches report several investigations related to the thermal stress analysis and fatigue life in the cylinder heads. Ashouri studied fatigue cracks of cylinder heads in diesel engines using the two-layer viscoplasticity model. His simulation showed that valve bridge is serious region [16]. Evaluation of viscosity effects on thermo-mechanical analysis for cylinder heads was performed by the two-layer viscoplasticity model. The obtained finite element analysis (FEA) results showed that the viscosity strain is more than plastic strain which is not negligible [17]. Chen et al. established the simulation approach for the fatigue life assessment of cylinder heads with integrated exhaust manifolds. Their research proved an acceptable between experimental and simulation results [6]. Thermo-mechanical analysis of a coated cylinder heads via the two-layer viscoplasticity model was done by Ashouri. His study disclosed that thermal barrier coatings decrease stress distribution in the cylinder heads [18]. A new fatigue life model for copper aluminum-silicon alloys was presented by Beranger et al. For the critical regions, neglecting ageing effect leads to an acceptable between experimental and simulation results [19]. Satyanarayana et al. used stress analysis to optimization the variable compression ratio of diesel engines cylinder heads. Their simulation showed that the optimum thickness of the part body is 15 mm [20]. Failure analysis of the cast cylinder heads was performed by Jing et al. Their study proved that the failure of the cylinder heads is mainly caused by the thermal fatigue [21]. In another attempt, Fonte et al. analyzed cracked cylinder head studs. Their research revealed that the main reason for crack initiation in studs is high stress concentration at second thread root of the studs [22]. Seifert et al. predicted fatigue life of aluminum cylinder heads considering ageing effects. Their research proved that ageing plays a significant role in the thermo-mechanical fatigue [3]. A complete simulation and analysis process of cylinder heads TMF was carried out by Zeng et al. The TMF analysis proved that the lowest thermo-mechanical fatigue occurs in the intake-exhaust valve bridge [8]. Wang et al. predicted TMF of turbocharged engines cylinder heads.

Their simulation showed that the location with low safety factor and TMF is in accord with the cracking location in the experimental tests [5]. Assessing TMF of a aluminum cylinder head was done by Liu et al. Their research proved that the damage due to creep is minimal and can be neglected [2]. Pingale et al. developed a finite element method and HCF to analysis the failure of cylinder heads. Their simulation revealed that the difference between experimental and simulation results is less than 11% [23]. Fatigue life prediction of diesel engines cylinder heads based on thermal fluid solid coupling model was done by Zhang et al. According to the their research the gas pressure and HCF are the dominated factors affecting the fatigue life of the engines cylinder heads [1]. Ikeda et al. experimentally measured the residual stress in aluminum cylinder heads and compared with simulated results. There is concordance between experimental and calculated residual stress [14].

In the literature although lots of researches focused on thermal stress analysis and fatigue life prediction of cylinder heads, there is a lack of information in the field of assessing thermal stress analysis and fatigue life prediction in cylinder heads considering the residual stress. Residual stresses have an important role on cylinder heads fatigue life. Residual stress leads to reduce the strength reliability such as deformation of cylinder heads during manufacturing and occurrence of cracks [10, 13, 14]. Thus, this paper goal is to study the stress analysis and fatigue life prediction considering residual stress in engines cylinder heads. For this purpose, Solidworks software was used to model the cylinder heads. Then the thermo-mechanical analysis was done to determine the temperature and stress distribution in ANSYS Workbench software. Finally, the fatigue life evaluation that considers residual stresses effect was performed.

2. Methodology

2.1 The material and its behavioral model

The material used for the cylinder heads is aluminum alloy A356.0. Temperature dependent stress-strain curves have been taken from experimental results of [17].

Residual stresses of a heat treated engine cylinder head happen from quenching [9, 10, 12, 14]. During quench, a cylinder head being solution treated about 500°C is cooled down to room temperature with high cooling rate [10, 12]. Water is a popular quench medium which creates large residual stresses inside quenched part [10,

24, 25]. The thermal strain created by temperature changes can be determined as follows [12]:

$$\varepsilon = \alpha \Delta T \quad (1)$$

Where α is the coefficient of thermal expansion and ΔT is the temperature difference. Prediction of temperature distribution during quenching is defined by Fourier's heat equation as below [12]:

$$\frac{\partial}{\partial x} \left(k \frac{\partial T}{\partial x} \right) + \frac{\partial}{\partial y} \left(k \frac{\partial T}{\partial y} \right) + \frac{\partial}{\partial z} \left(k \frac{\partial T}{\partial z} \right) = \rho c \frac{\partial T}{\partial t} \quad (2)$$

Where k , ρ and c are the thermal conductivity, density and specific heat, respectively. The residual stresses is expressed by Hook's relation on strain in each direction [15]:

$$\sigma_{x,y,z} = \frac{E}{1+\nu} (\varepsilon_{x,y,z} + \frac{\nu}{1-2\nu} (\varepsilon_x + \varepsilon_y + \varepsilon_z)) \quad (3)$$

Where E is the modulus of elasticity, ν is Poisson's ratio, σ is the residual stress in the x , y and z principal axes, and ε is the strain in the x , y , and z principal axes. A nonlinear isotropic-kinematic hardening material approach is applied in this article. When the material is yielding the relation of yield surface (f), is defined by the following expression [26]:

$$f = \sqrt{\frac{3}{2}} (S - X') (S - X') - R - k = 0 \quad (4)$$

Where S and X' are deviatoric parts of stress and back stress tensors respectively, R is isotropic hardening variable, and k is the initial size of the yield surface. Assessment of back stress tensor as follows [26]:

$$\dot{X}_i = \frac{2}{3} C_i \dot{\varepsilon}_p - \gamma_i X_i \dot{p} + \frac{1}{c_i(T)} \frac{\partial C_i}{\partial T} X \dot{T} \quad (5)$$

Where C and γ are material properties. The term $\gamma_i \dot{p}$, called the dynamic recovery, causes the nonlinear response of the stress-strain behavior. Overall back stress tensor is a linear combination of individual back stress tensors, as below [26]:

$$X = \sum_{i=1}^m X_i \quad (6)$$

Where i is number of back stress tensors. Evolution of isotropic hardening variable (R), with material constants Q and b is defined by relationship:

$$\dot{R} = b(Q - R)\dot{p} \quad (7)$$

2.2. Models for thermo-mechanical life prediction

For cylinder heads the temperature fluctuations arising from on and off engine cycles created by start-stop operation and load changes during vehicle operation creates the TMF. The fatigue life evaluation of TMF loading cases has received considerable attention in recent years in cylinder heads development [1-5].

TMF damage is defined by the classical fatigue mechanisms. These include nucleation, initiation and propagation due to the strain amplitude. Since the cyclic plastic strain is remarkable, strain-life approach is used to prediction fatigue life. The fatigue life term, N_f is estimated with Coffin-Manson-Basquin equation as follows [27, 28]:

$$\Delta \varepsilon = \frac{\Delta \varepsilon_e}{2} + \frac{\Delta \varepsilon_p}{2} = \frac{\sigma'_f}{E} (2N_f)^b + \varepsilon'_f (2N_f)^c \quad (8)$$

Where σ'_f is the fatigue strength coefficient, b is the fatigue strength exponent, ε'_f is the fatigue strength coefficient and c is the fatigue ductility exponent fatigue ductility exponent.

The stress-strain state has to be fully reversed in order to use the Coffin-Manson-Basquin equation for fatigue life analysis directly. It has been proven that the mean stress level has a significant role on fatigue performance. Therefore, the results need to be corrected for mean stress effects. There are two main strain based approaches used widely in engines industry [2, 5, 6, 7], Smith-Watson-Topper equation and Morrow equation [27, 28]:

$$E \varepsilon_a \sigma_{n,max} = (\sigma'_f)^2 (2N_f)^b + (E \sigma'_f \varepsilon'_f)^* (2N_f)^{b+c} \quad (9)$$

$$\Delta \varepsilon = \frac{\Delta \varepsilon_e}{2} + \frac{\Delta \varepsilon_p}{2} = \frac{\sigma'_f \sigma_{mean}}{E} (2N_f)^b + \varepsilon'_f (2N_f)^c \quad (10)$$

Where ε_a is the maximum principal strain amplitude, $\sigma_{n,max}$ is the maximum normal stress acting on maximum principal strain amplitude plane.

2.3. The finite element model and material properties

FEA provides accurate and reliable assessment of stress and fatigue life results in the cylinder heads. Finite element analysis allows engineers to detect structural defects at the primary step or to understand the root reason of cylinder head failures [1,8, 16, 17]. The cylinder heads studied in this paper are exhibited in Fig. 1.

Engines cylinder heads are made of cast aluminum alloy (A356.0), with a Young's modulus of 70GPa, a Poisson's ratio of 0.33. The

Evaluation of quenching process on low cycle fatigue life for cylinder head

four valve seats are made of steel, with a Young's modulus of 200GPa and a Poisson's ratio of 0.3 [16, 17].

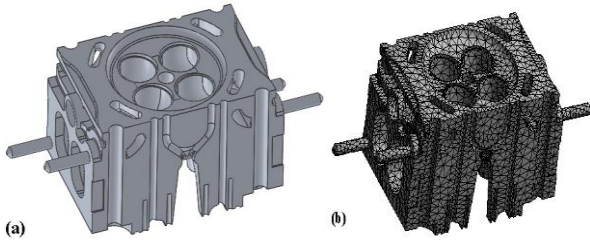

Figure 1: (a) The cylinder head generated by SolidWorks, (b) Finite element model of the cylinder head

3. Results and Discussion

3.1. Thermal Analysis

Finite element thermal analysis is to evaluation temperature field in the cylinder heads. For engines cylinder heads, the main factor of the loading is the thermal prediction of the cylinder heads in operating engines conditions [3, 5, 7, 16, 17]. The correct estimation of the temperature distribution is the most important step for the fatigue life evaluation of the cylinder heads [1,3,4,5,7]. Cylinder heads thermal boundary conditions consist of the areas of combustion chamber, inlet duct, exhaust duct, areas contacting oil and areas contacting air [21, 30, 31]. In this way, the area of combustion chamber was estimated to be 959°C with a convection coefficient of 1027W/m²K. The inlet duct was defined as 30°C with convection coefficient of 320W/m²K. The exhaust duct was estimated as 650°C with convection coefficient of 640W/m²K. The areas contacting oil was specified as 60°C with a convection coefficient of 150W/m²K. The areas contacting air was defined as 30°C with a convection coefficient of 60W/m²K [21].

The resulting temperature distribution on the cylinder heads is given in Fig. 2. Temperature distribution has an important impact on the fatigue life prediction and the temperature distribution shows serious areas. The maximum temperature occurs in the bridge region between the exhaust valves. This corresponds to the results by [1, 3, 5, 6, 8, 21, 29, 30, 31].

Fig. 3 gives the temperature gradient in the exhaust and exhaust-intake valve bridges of the cylinder heads. It is obvious that gradient on Path 1 is greater than that on Path 2. The maximum temperature in the valve bridge between the two exhaust valves reaches to 206°C, which is within the limit of acceptance for aluminum material [8].

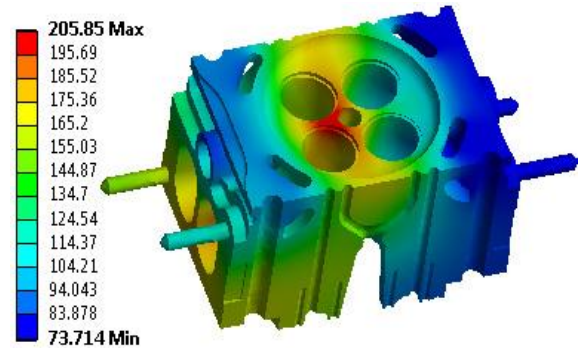

Figure 2: The temperature distribution in the cylinder head

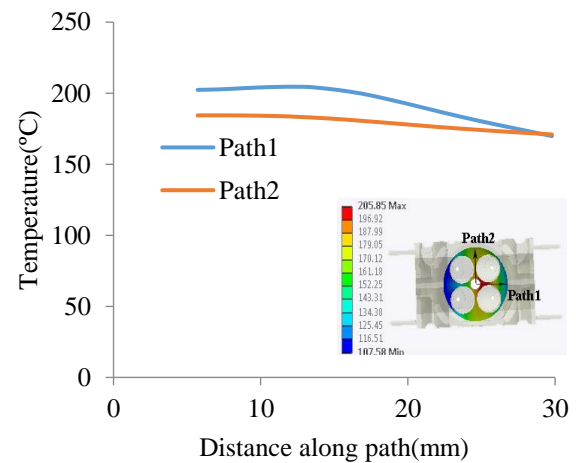

Figure 3: Temperature gradient in the exhaust and exhaust-intake valve bridges

3.2. Mechanical analysis

The cylinder heads bear the mechanical stress and withstands the thermal stress caused by the temperature fluctuations. Therefore, the analysis of thermo-mechanical coupling stress on the cylinder heads is essential [1, 2, 3, 5, 6, 8]. The loads of the thermo-mechanical coupling stress analysis of the engines cylinder heads include gas pressure, bolt preload, thermal load calculated from thermal analysis and loads caused by press-fitting of the seat valves [1, 5, 7, 30].

Import the simulated results of the cylinder heads temperature and impose the mechanical stress [1, 2, 3, 5, 6, 8, 16, 17, 18]. Then finite element calculation is performed and the results are investigated. It is assumed that the cylinder heads are fixed to the engine blocks, so the all degrees of freedom of bolt holes of cylinder heads were fully constrained [16, 17 ,18]. The structural boundary condition are shown in Fig. 4. Fig. 5 shows the equivalent stress field at end of second step.

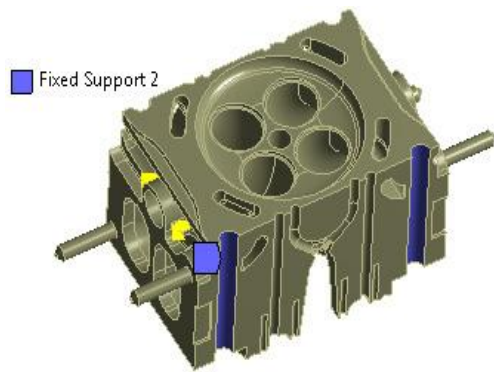

Figure 4: Structural boundary condition

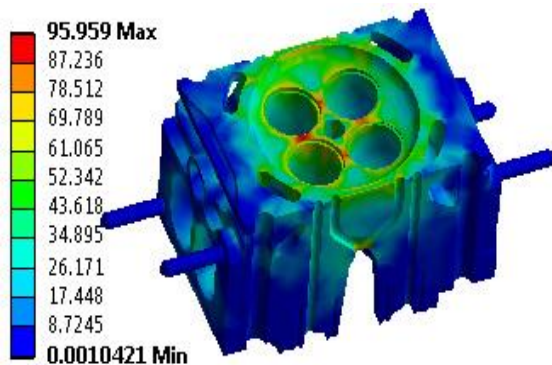

Figure 5: The Von-Mises stress distribution in the cylinder head

Analysis of the residual stress in the LCF cylinder heads is the main focus of this paper. Residual stresses play a key effect in the fatigue life cylinder heads. Therefore, higher accuracy evaluation of the residual stress is needed [10, 13, 14, 15, 24]. Von-Mises stress distributions are exhibited in Figs. 6 and 7 for quench process and for quench process plus thermo-mechanical loading, respectively. Based on the study by Erpolat et al., the maximum value of the residual stress in the A356.0 cylinder head is 86.3Mpa. Comparing these results, proves a good agreement between residual stress analysis and simulated results carried out by Erpolat et al.

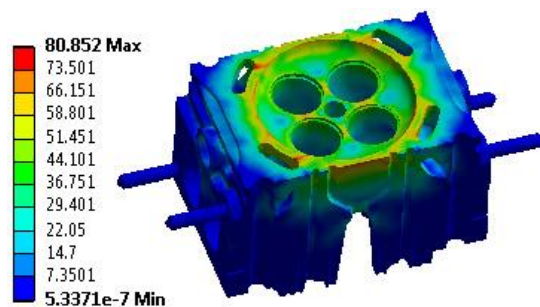

Figure 6: The Von-Mises stress distribution in the cylinder head under quench process (residual stress)

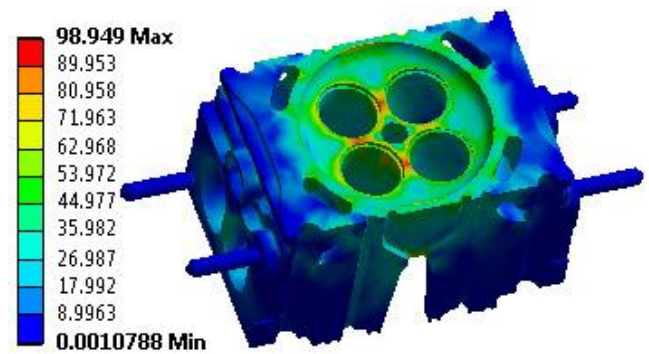

Figure 7: The Von-Mises stress distribution in the cylinder head under quench process (residual stress) plus thermo-mechanical loading

It can be seen from Figure 6 that the effect of residual stress is considerable. Thus, residual stress should be investigated in the FEA of the cylinder heads. Thermal plastic strain accumulates in the cylinder heads due to cyclic thermal stress, and that adversely affects the fatigue life of the cylinder heads [2, 3, 16, 17]. The equivalent plastic strain field in the cylinder heads is shown in Fig. 8. The equivalent plastic strain is larger than zero, showing that the material is currently yielding. The review of FEA results, it can be observed that the stress and plastic strain, which have key impact on the fatigue life prediction are maximum in the valve bridge between the two exhaust valves. This corresponds to the results by [2, 3]

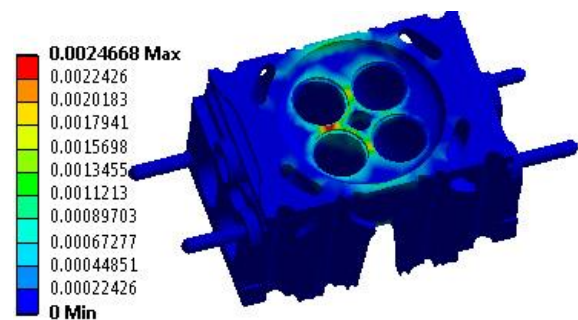

Figure 8: The equivalent plastic strain distribution

3.3. Low cycle Life prediction

One of the important issues of engines is cylinder head fatigue cracks at valve bridge area [1-4, 7, 16, 17, 18]. In cylinder heads, HCF is caused by the firing pressure and LCF is caused by plastic strain during engine operations. Eventually cracks can happen in the valves bridge regions. To avoid these failures, TMF should be performed to ensure long term cylinder heads durability [1, 4, 5, 6, 7, 30, 31]. The fatigue life evaluation has been done according to LCF

Evaluation of quenching process on low cycle fatigue life for cylinder head

equations, by using the Morrow and SWT method. Figs. 9 to 12 shows the number of cycles to failure based on Morrow and SWT criterion for cylinder heads, also considering the effect of the residual stress.

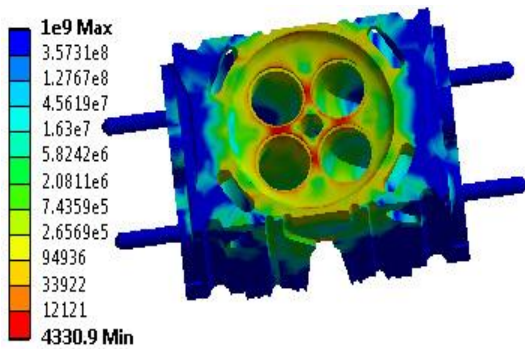

Figure 9: The number of cycles to failure based on SWT equation

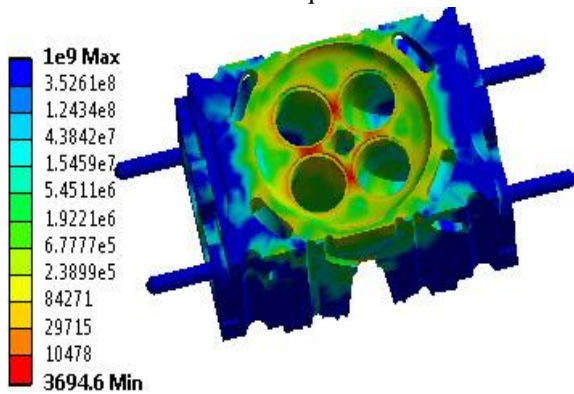

Figure 10: The number of cycles to failure using SWT equation with residual stress

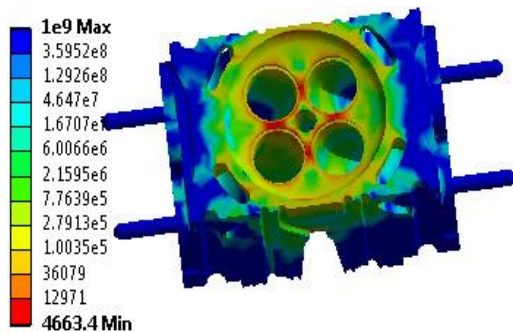

Figure 11: The number of cycles to failure based on Morrow equation

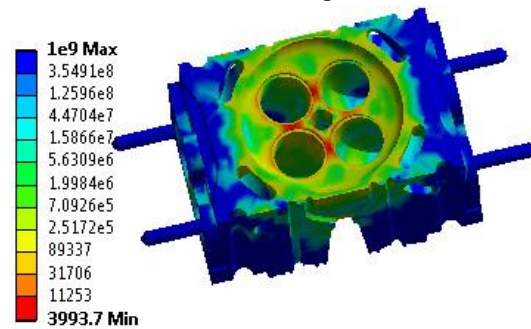

Figure 12: The number of cycles to failure using Morrow equation with residual stress

As it can be observed from Figs. 9 to 12, the number of cycles to failure in the serious regions is under 10^4 or 10^5 which proves LCF for the cylinder heads [27, 28]. The LCF results show that the residual stress reduces the fatigue life of the engines cylinder heads about 14% and 15% based on Morrow and SWT methods, respectively. The impact of residual stress in LCF is considerable. Thus, residual stress must be investigated in the thermo-mechanical fatigue analysis of the cylinder heads. Fig. 13 shows the failure position of cylinder heads in experimental tests. As observed in Figures 7, engines cylinder heads which has been cracked in the valve bridge between the two exhaust valves. The review of Figs. 2-12 proves that results of finite element analysis and low cycle fatigue life is corresponded with experimental tests performed by researchers, and demonstrated the cylinder heads cracked in this region.

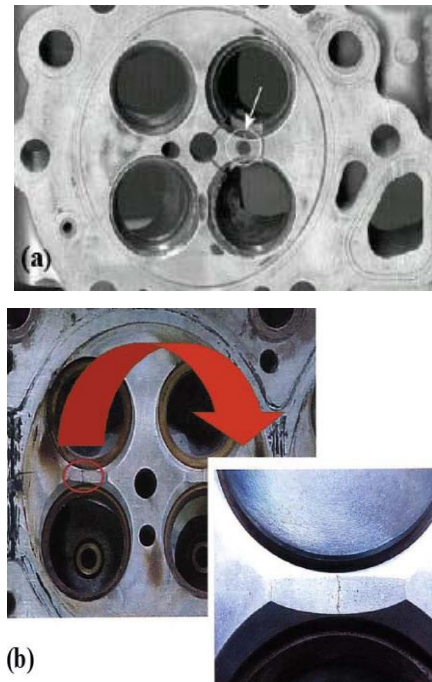

Figure 13: The cracked cylinder head, a[32], b[33]

4. Conclusion

It is proven that cylinder heads are exposed to low cycle fatigue due to the thermo-mechanical stresses resulted from repeated start-up stop-down cycles of the engines and must be studied via finite element analysis [1, 4, 5, 6, 7]. The objective of this article is to evaluate the effect of the residual stress on the LCF of cylinder heads using Morrow and SWT strain life equations. The thermo-mechanical analysis showed that the maximum temperature and stress happen in the valves bridge between the two exhaust valves. The results of the FEA correspond with experimental tests performed by researchers, and

demonstrated the cylinder heads cracked in this region. The numerical results showed that the impact of residual stress in LCF is considerable. Thus, residual stress must be investigated in the thermo-mechanical fatigue analysis of the cylinder heads. Better understanding of engines cylinder heads fatigue life can improve the development process of a new engine concerning computer aided engineering as well as mechanical testing efficiency.

References

- [1] H. Zhang, Y. Cui, G. Liang, L. Li, G. Zhang, X. Qiao, Fatigue life prediction analysis of high-intensity marine diesel engine cylinder head based on fast thermal fluid solid coupling method, *Journal of the Brazilian Society of Mechanical Sciences and Engineering*, <https://doi.org/10.1007/s40430-021-03049-7>, (2021)
- [2] Y. Liu, P. Annabattula, S. Mirmiran, L. Zhang, J. Chen, S. Gaikwad, K. Singh, Assessing Thermo-mechanical Fatigue of a Cast Aluminum Alloy Cylinder Head of an Internal Combustion Engine, *SAE Technical Paper No.2020-011077*, (2020).
- [3] T. Seifert, R. Hazime, C-C. Chang, C. Hu, Constitutive Modeling and Thermo-mechanical Fatigue Life Predictions of A356-T6 Aluminum Cylinder Heads Considering Ageing Effects, *SAE Technical Paper No.2019-01-0534*, (2019)
- [4] W-J. Lai, C. E-P, Development of a Thermal Fatigue Test Bench for Cylinder Head Materials, *SAE Technical Paper No.2018-01-1410*, (2018).
- [5] Y. Wang, Z. Xu, M. Chen, Thermo-Mechanical Fatigue and Life Prediction of Turbocharged Engine Cylinder Head, *SAE Technical Paper No.2020-01-1163*, (2020).
- [6] M. Chen, Y. Wang, W. Wu, Q. Cui, K. Wang, L. Wang, Thermal-Mechanical Fatigue Prediction of Aluminum Cylinder Head with Integrated Exhaust Manifold of a Turbo Charged Gasoline Engine, *SAE Technical Paper No.2016-01-1085*, (2016)
- [7] A. Ghasemi, Cylinder Head High/Low Cycle Fatigue CAE Analysis, *SAE International Paper No.2012-01-1999*, (2012).
- [8] X. Zeng, X. Luo, G. Jing, P. Zou, Y. Lin, T. Wei, X. Yuan, H. Ge, Engine Cylinder Head Thermal-Mechanical Fatigue Evaluation Technology and Platform Application, *SAE International Journal of Engines*, Vol. 13, No. 1, (2020), pp.101-120.
- [9] S. ERPOLAT, D. MANAV, A. TEKELI, C. SEVER, INCORPORATING RESIDUAL STRESSES INTO THERMO-MECHANICAL FATIGUE ANALYSIS OF CYLINDER HEAD, *Proceedings of the ASME 2010 10th Biennial Conference on Engineering Systems Design and Analysis ESDA2010*, Turkey, (2010).
- [10] Q. Wang, C-C, Chang, G. zhang, D. Paluch, Modeling of Residual Stresses in Quenched Cast Aluminum Components, *SAE Technical Paper No.2011-01-0539*, (2011).
- [11] S. Ahmad, D. Sediako, A. Lombardi, C. Ravindran, R. Mackay, a A. Nabawy, Assessment of Residual Stress in T5 Treated 319 Aluminum Alloy Engine Blocks Using Neutron Diffraction, *SAE Technical Paper No.2016-01-0353*, (2016).
- [12] B. Kim, A. Egner-walter, H. Chang, ESTIMATION OF RESIDUAL STRESS IN CYLINDER HEAD, *International Journal of Automotive and Technology*, Vol.7, No. 1, pp.69-74, 2006
- [13] Z. Quan, Z. Gao, Q., Wang, X. Wen, Y. Wang, B. Xiao, Rapid Residual Stress and Distortion Prediction in Cast Aluminum Components Using Artificial Neural Network and Part Geometry Characteristics, *SAE Technical Paper No.2014-01-0755*, (2014).
- [14] T. Ikeda, S. Hirose, H. Uozumi, K. An, Y. Chen, A. Seid, T. Okayama, T. KATSURAI, Residual Stress Analysis for Additive Manufactured Large Automobile Parts by Using Neutron and Simulation, *SAE Technical Paper No.2020-01-1071*, (2021).

Evaluation of quenching process on low cycle fatigue life for cylinder head

- [15] S. Kianfar, J. Stroh, N. Bahramian, D. Sediako, A. Lombardi, G. Byczynski, P. Mayr, M. Reid, and A. Paradowska, Residual Stress Prediction in the Casting Process of Automotive Powertrain Components, Materials Society, https://doi.org/10.1007/978-3-030-65396-5_113, pp. 858-864, (2021).
- [16] H. Ashouri, Finite element analysis of thermo-mechanical stresses in diesel engines cylinder heads using a two-layer viscoplasticity model, International Journal of Automotive Engineering, Vol.5, No.4, pp.2054-2064, (2015).
- [17] H. Ashouri, Thermo-mechanical analysis of fatigue cracks of diesel engines cylinder heads using a two-layer two-layer viscoplasticity model with considering viscosity effects, International Journal of Automotive Engineering, Vol.6, No.2, pp.2163-2175, (2016).
- [18] H. Ashouri, 2017, Thermal barrier coating effect on stress and temperature distribution of diesel engines cylinder heads using a twolayer viscoelasticity model with considering viscosity, International Journal of Automotive Engineering, Vol.7, No.2, (2017), pp.2380-2392.
- [19] M. Beranger, J-M. Fiark, K. ammar, G. Ccailetaud, A new fatigue model including thermal ageing for low copper aluminum-silicon alloys, Procedia Engineering, Vol.213, (2018), pp. 720-729.
- [20] K. Satyanarayana, T-V. Hanumantha Rao, Response optimization of four stroke variable compression ratio diesel engine cylinder head with stress analysis, Materials Today: Proceedings, Vol.5, pp.19497-19506, (2018).
- [21] G-X Jinga, M-X. Zhang, S. Qub, J-C Pangb, C-M. Fub, C. Donga, S-X. Lib, C-G. Xua, Z-F. Zhangb, Investigation into diesel engine cylinder head failure, Journal of Engineering Failure Analysis, Vol. 90, (2018), pp. 36-46.
- [22] M. Fontea, L. Reis, V. Infanteb, M. Freitas, Failure analysis of cylinder head studs of a four stroke marine diesel engine, Journal of Journal of Engineering Failure Analysis, Vol.101, (2019), pp.298-308.
- [23] A. Pingale, C-Chi Chang, J. Perander, Data Driven Model to Predict Cylinder Head Fatigue Failure, SAE Technical Paper No. 2021-01-0801, (2021).
- [24] X. Su, J. Lasecki, J. Jan, C. Engler-Pinto Jr, J. Allison, Residual Stress Analysis of Air-Quenched Engine Aluminum Cylinder Heads, SAE Technical Paper No.2008-01-1240, (2008).
- [25] A-A. Ebrinç, Simulation and Measurement of Residual Stresses for HCF Cracks on LPDC Aluminum Cylinder Head, SAE Technical Paper No.2008-01-1091, (2008).
- [26] J. L. Chaboche, A review of some plasticity and viscoplasticity constitutive theories, International Journal of Plasticity, Vol. 24, (2008), pp.1642-1693.
- [27] R. Stephens, A. Fatemi, H. Fuchs. Metal fatigue in engineering, 2nd edition, John Wiley, (2001).
- [28] Y. L. Lee, J. Pan, R. B. Hathaway, M. E. Barkey, Fatigue Testing and Analysis:Theory and Practice, Elsevier Butterworth-Heinemann, (2005).
- [29] A. Basiri, M. Azadi, F. Moghaddam, Finite element analysis of fatigue damage in passenger-car diesel engine cylinder head under cyclic thermo-mechanical loadings, The Journal of Engine Research, Vol. 51, (2018), pp. 03-19.
- [30] G. Xuyang, Y. Cheng, Z. Zhang, Thermo-mechanical fatigue life prediction of heavy duty diesel engine cylinder head, ASME International Mechanical Engineering Congress and Exposition, California, U.S.A, (2013).
- [31] M. Metzger, M. Leidenfrost, E. Werner, H. Riedel, T. Seifert, Lifetime Prediction of EN-GJV 450 Cast Iron Cylinder Heads under Combined Thermo-mechanical and High Fatigue Loading, SAE International Paper No.2014-01-9047, (2014).

[32]T. Takahashi, K. Sasaki, 2010, Low cycle fatigue of aluminum alloy cylinder head in consideration of changing metrology microstructure, Journal of Procedia engineering, Vol.2, pp.767-776, (2010).

[33] M. Angeloni 2011, Fatigue life evaluation of A356 aluminum alloy used for engine cylinder head, Ph.D. Thesis, University of Sau Palu, Brazil, (2011).