



DESIGN AND CONSTRUCTION OF A RACING GO-KART: THE BRAKING SYSTEM

Ihe, Godswill Chidi¹, Okuma Silas Oseme^{2*}

¹Department of Mechanical Engineering, Federal University of Technology, Owerri, Imo State, Nigeria.

²Department of Mechanical Engineering, Nigeria Maritime University, Okerenkoko, Delta State, Nigeria.

ARTICLE INFO

Article history:

Received : 5 Aug 2022

Accepted: 20 Sep 2022

Published: 10 Nov 2022

Keywords:

Go-Kart

Design

Simulation

Braking

Automobile

ABSTRACT

Go-karts are popular sport mini-car in western countries, and there are gaining prominence in developing countries such as Nigeria. Its performance is determined by the chassis design and the braking system is its lifeline. Because of the lack of a suspension system and differentials, a good chassis must be able to bend and twist.

This Go-kart is powered by a Yamaha Vino Automatic Petrol 2-stroke Engine that generates approximately 4.1kw of power at 9018rpm. It boasts slick tyres for increased grip and a hydraulic disc brake for smooth and effective braking in both wet and dry conditions. The focus of this paper is on the braking system and material characterization of its structural members

Simulation static study with Autodesk Inventor yielded the following results: Mass Density 281.550 lbmass/ft³ Yield Strength 40.000 ksi Ultimate Tensile Strength 50.000ksi. Design calculations were performed, and the best possible result was obtained. Ergonomics, safety, cost of manufacturing, and reliability are all considered.

Introduction

A Go-kart is a single-seat racing automobile with four wheels and a small engine that is popular in the US. Airmen invented these as a way to pass the time during the 1950s and postwar years. By definition, a Go-kart has no suspension and no differential. Although they are typically raced on smaller tracks, non-professionals may drive them for fun or as a hobby. Karting is the first step in any serious racer's career.

Engineers are actively developing and adjusting more reliable automobiles in the modern period to make them safer by

improving the design and materials. Various tests, including load testing, are carried out to assess the vehicle's performance. These loading tests take into account front, rear, and impact effects. Vibrations and stresses of various kinds are avoided. These days, go-kart testing and analysis are more important than theoretical conclusions, as this type of vehicle is used in racing and requires a high level of safety.

*Corresponding Author

Email Address: silasoseme@gmail.com(Okuma Silas Oseme)
<http://doi.org/10.22068/ase.2022.610>

Because they are less costly and smaller than traditional racing cars, they have become more popular than other racing and sports vehicles. It's becoming increasingly popular among kids, adults, and the elderly. This sector is rapidly expanding and has a promising future.

The braking system is an important feature of a racing automobile since it allows the car to decelerate in bends while also bringing it to a complete stop. Due to the tremendous heat dissipated causing friction near the tyres, this system of a car suffers significant wear and tear as the most active component. In the case of a Go-kart racing automobile, however, braking effectiveness takes precedence above wear and tear. Furthermore, because the automobile is to be produced in a smaller number for a renowned event, pricing is not a high issue in this situation. Unlike passenger automobiles and other racing cars, Go-karts have lower body weight, which is nearly equivalent to the driver's weight, 75% of the weight of the complete body is provided by the engine, which is equally heavy to a two-wheeler engine [1].

Mitchell et al evaluated a Go-karts design and discovered that the vehicle's base is the center distance, which is the distance between the front and back wheels. This means that if the vehicle's base is large, it has more consistency and reliability. Varied types of Go-kart designs had different criteria for evaluating vehicle stability, according to the study. The study also concluded that Go-kart research and development should not be halted since designs must be changed over time [2]. The aerodynamic properties of the vehicle were researched by Hajare et al. They studied how the vehicle's body should be designed utilizing aerodynamic principles, as well as how the engine should be properly packed. Following two measures will significantly increase the vehicle's speed. When it comes to speed, the braking system

should be chosen carefully to match the vehicle's speed [3].

Following the criteria to demonstrate practical talents and use theoretical knowledge in the design of machine elements to contribute to the car industries in Nigeria, local kart enthusiasts and operators have no choice but to import them from overseas. As a result, the price immediately rises, discouraging some fans and enthusiasts from taking part in the sport., it is, therefore, difficult to overestimate the advantages of using a racing Go-kart. In a nation like Nigeria, where Go-karts have yet to attain complete acceptance and draw significant investment in design and development, it is estimated that roughly 15% of the population uses or visits amusement parks or recreational facilities [4]. It can also be a source of income for citizens who are unskilled, semi-skilled, or skilled. Consider where some of the local engineers are employed in the mass manufacture of entertainment and racing Go-karts. There is a certainty that GDP will increase, and that this will broaden our economic base (particularly in soccer contests and other sporting events), as many business-minded individuals will seize the chance to create wealth for themselves, their families, and the country [5]. The purpose of this project was to construct a unique Go-kart based on a concept design that was modified to improve the vehicle's stability. Go-karts design and construction focus on creating a vehicle that is simple, light, and easy to control. The key features were ergonomics, safety, and reliability. Both primary components were analyzed in order to improve vehicle performance and strength and reduce manufacturing complexity and costs.

2. Design Material and Procedure

Mild steel was selected in the fabrication process, as a result, lightweight, high strength,

Table.1.Mild Steel Properties

Ultimate tensile strength	834Mpa
Yield tensile strength	231Mpa
Density	7.87g/cc

2.2. Design Considerations

To design and fabricate a high-performance racing vehicle that is ergonomically, economically, and in every other way safe, main parameters such as driver ergonomics, serviceability, maneuverability, design of a flexible roll cage, and use of maximum power efficiency are taken into account during the design process [6].

2.3. Chassis Design

The chassis structure was built to support the weight of the driver, bump loads (the frameworks as a suspension in karts), and engine weight. To shorten the kart, brake and accelerator pedals were positioned at the extreme front position. It's also necessary to keep a 3-inch ground clearance.

2.4. Steering System

The steering system's major purpose is to give directional control with a small turning radius. The key design objectives were mounting convenience, a small frame, and simplicity in design. The steering system's steadiness and response time are critical aspects in determining the vehicle's performance [7].

2.5. Engine Selection

A Go-kart's engine is usually quite small. The Yamaha vino automated petrol engine, which provides roughly 4.1kw of power at 9018rpm, is employed in this kart. For racing, a 2-stroke engine is utilized. The power train

2.1.Material Selection

relative availability and low cost. The table below shows the mild steel properties.

Elongation of break	16%
Bulk Modulus	132Gpa
Poisons Ratio	0.278
Shear modulus	78Gpa

is responsible for the Kart's velocity, acceleration, and torque. The chain drive transmits the motor's power to the driving shaft.

2.3. Manufacturing Process

The manufacturing procedures for this Go-kart involve the following process: Cutting, Drilling, Filing and welding process.

2.6. Transmission

Power used up is produced by the chain connected to the sprockets, making it a chain drive vehicle. There are 15 teeth on the driver sprocket and 45 teeth on the driven sprocket. This Go-kart also lacks a clutch and gears due to the automated gearbox. To transmit mechanical power to the rear two wheels, the chain drive mechanism is employed considering its ability to withstand stress loads, the higher impact for a shorter distance transmission and suitability for all conditions.

2.7.Tyres

Wheels and tyres on Go-karts are substantially smaller than those on regular automobiles. These tyres provide more grip and are more durable. It can also endure high temperatures. The front tyres on this kart are 11" in diameter, while the rear tyres are 13" in diameter. This is utilized to create an aerodynamic form. The pressure in the tyres must be at least 18 psi.

2.8. Brake System Analysis

Vehicle brake system is regarded as an energy dissipation device, which converts kinetic energy into thermal energy (heat). The main function of the brakes is speed control, and the rate of energy dissipation defines the vehicle's deceleration rate[8].

Braking is an essential safety component of the vehicle, the system has evolved over the years in achieving a higher safety

3.0 Result and Discussion

3.1.1 Brake System Calculations

When a moving vehicle is halted or slowed down, the kinetic energy it possesses is determined by its weight and speed. The brake system works in a way, such that, the resistance generated by the caliper plate on the brake disc as the vehicle brakes changes the net kinetic energy into heat. The vehicle's kinetic energy is calculated using the equation;

$$\text{Kinetic energy, } = \frac{1}{2} m v^2$$

Taking:

Mass of the vehicle, m as 180kg; Velocity of the vehicle, as 16.67ms^{-1} ; and Kinetic energy as 25.01KJ

When rotational, energy absorbed, $E = \frac{1}{2} I (\omega)^2$

Where I = mass moment of inertia, ω = angular velocity

As the vehicle slows down, it is estimated that the coefficient of friction, μ for the contact area between tyre and road does not exceed 0.6. And with this we assumed the braking of the vehicle to be 5.88ms^{-2} .

Following Newton's law of motion, the distance at which the vehicle will stop can be calculated.

$$v^2 = u^2 + 2as$$

Taking:

The initial and final velocity to be, v and u ; the acceleration to be, a and s as the distance of the vehicle.

performance and efficiency[9-10]. The forces required for braking are estimated using the Go-kart car's available braking standards and the vehicle characteristics. In addition, the location of the brake caliper is established. Because the mounting positions and features of the vehicle chassis are unknown, the mounting position is not taken into account when the static analysis is done just on the brake caliper assembly.

Taking v to be 0 when the brake is applied; the initial velocity, u will be 16.67ms^{-1} . And the vehicle slow down by 5.88ms^{-2} . Hence, braking distance, $s = 23.63 \text{m}$

Also, from proceeding above and to calculate the time to stop the vehicle, and from Newton's law. We use that: $v = u + at$

Taking, v to be 0; u as 16.67ms^{-1} , and stopping distance as 23.63 m, hence, $t = \frac{u}{a}$ and $t = 2.84 \text{s}$

Hence, the stopping time is 2.84s within 23.63m

3.2. Braking Force model

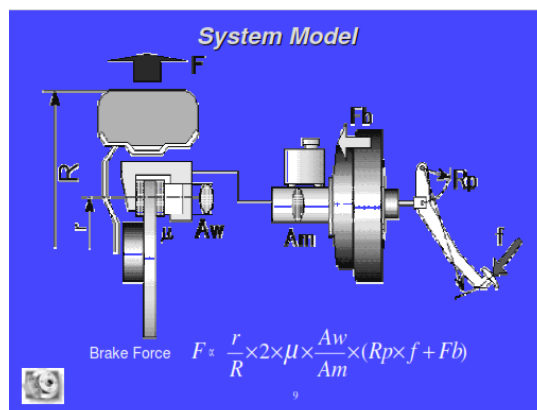

Figure.1. Illustrates the force path from the driver's foot to the road interface

- f = force applied by the driver's foot
- R_p = lever ratio for the pedal
- F_b = booster assist force
- A_m = area of the master cylinder
- A_w = front caliper piston area

μ = lining friction coefficient
 r = effective radius of the caliper
 R = loaded radius of the tire.

The pressure (psi) in a hydraulic braking system is determined by the effort or force applied to the brake pedal, as well as the output of the booster and the diameter of the master cylinder pistons. The higher the pressure for a given power on the brake pedal, the smaller the master cylinder bore diameter. A smaller master cylinder, on the other hand, would need longer piston movement to displace the same quantity of fluid as a larger piston. The larger the force acting on the brake shoes, the larger the diameter of the wheel hub or caliper piston. Obtaining correct information on the caliper effective radius and/or the tire loaded radius might be challenging at times.

Conversely, the braking force can be calculated using the formula

$$\text{Work done} = \text{force} \times \text{distance}$$

$$\text{Force} = \frac{25010}{23.63}$$

$$\text{Force} = 1058.4\text{N}$$

Brake Torque = Brake Force \times Effective radius of the rotor

$$\text{Effective radius} = \frac{D + d}{4} = \frac{16 + 2.54}{4} = 4.635\text{cm}$$

$$\text{Brake torque} = 1058.4 \times 0.04635 = 49.06\text{Nm}$$

By approximation, the amount of force the drive applies on the pedal is taken as 100 N and the ratio of the pedal is 4:1.

The master cylinder piston area is 1cm^2 .

$$\text{Brake Pressure} = \text{pedal ratio} \times \text{pedal force} \\ = 4 \times 100 = 4000\text{KN/m}^2$$

$$\text{Area of cylinder piston} = 0.0001\text{m}^2$$

Table 2: shows calculated data for the braking system

Disk outer diameter	16cm
Disk inner diameter	2.54cm
Thickness of disk	0.3cm
Brake pedal force	100N

Pedal ratio	4: 1
Coefficient of friction	0.60
Brake line pressure	4000KN/m ²
Brake torque	49.06Nm
Stopping distance	23.63m
Stopping time	2.84s

With the above values, the braking system will function properly and meet the requirements. An Aluminum metal matrix composite was used as appropriate material for the brake disc system due to its less fuel consumption and low specific gravity. The amount of energy absorbed by a brake is determined by the moving body's form of motion (speed). A body's motion can be pure translation, pure rotation, or a mix of both translation and rotation [11].

3.3 Simulation Type : Static Analysis

CHASSIS

Material(s)

Name	Titanium	
General	Mass Density	281.550 lbmass/ft ³
	Yield Strength	40.0 ksi
	Ultimate Tensile Strength	50.0 ksi
Stress	Young's Modulus	14921.63 ksi
	Poisson's Ratio	0.361 ul

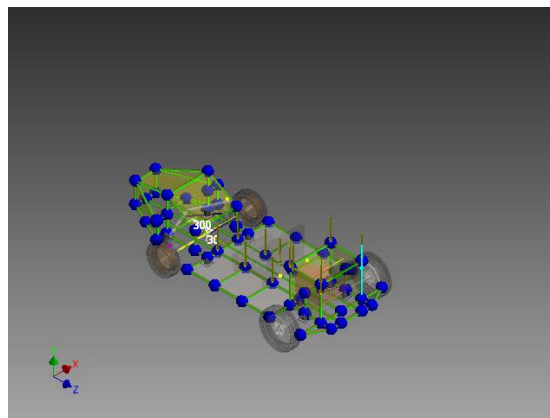

Figure.2. Force.1simulation Analysis

Mechanical Properties	Moment of Inertia (I _x)	0.037 in ⁴
	Moment of Inertia (I _y)	0.037 in ⁴
	Torsional Rigidity Modulus (J)	0.074 in ⁴
	Section Modulus (W _x)	0.071 in ³
	Section Modulus (W _y)	0.071 in ³
	Torsional Section Modulus (W _z)	0.141 in ³
	Reduced Shear Area (A _x)	0.168 in ²
	Reduced Shear Area (A _y)	0.168 in ²
	Part Name(s)	ANSI 3_4 x 0.113 00000065.ipt
		ANSI 3_4 x 0.113 00000067.ipt

Force Analysis 1

Type of load	Force
Magnitude	150.0 lbf
Beam Coordinate System No	
Angle of Plane	270.0 deg
Angle in Plane	90.0 deg
F _x	0.0 lbf
F _y	-150.0 lbf
F _z	0.0 force

Force Analysis 2

Type of Load	Force
Magnitude	100.0 lbf
Beam Coordinate System No	
Angle of Plane	270.0 deg
Angle in Plane	90.0 deg
F _x	0.0 lbf
F _y	-100.0 lbf
F _z	0.0 lbf

Operating conditions

Gravity

Load Type	Gravity
Magnitude	386.22 in/s ²
Direction	Y-

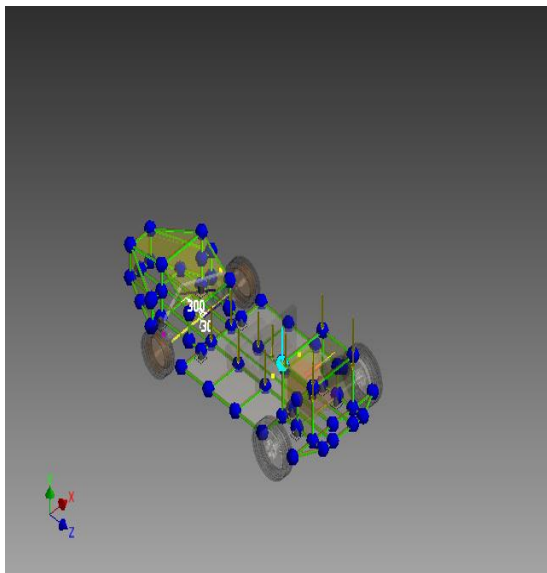
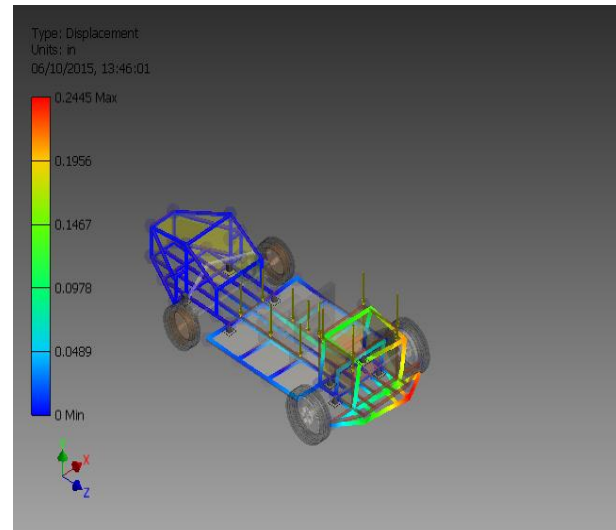

Figure.3:simulation Analysis

Torsional Stresses T -2.707 ksi 2.328 ksi

Figure.4:Inventor Displacement Diagram



3.4 Static Result Summary

Name	Minimum	Maximum
Displacement	0.000 in	0.244 in
Forces	Fx lbforce	22.430 lbforce
	Fy lbforce	1481.109 lbforce
	Fz lbforce	1121.588 lbforce
Moments	Mx lbforce in	2193.528 lbforce in
	My lbforce in	246.441 lbforce in
	Mz lbforce in	718.580 lbforce in
Normal Stresses	Smax	36.857 ksi
	Smin	0.004 ksi
	Smax(Mx)	36.799 ksi
	Smin(Mx)	-0.000 ksi
	Smax(My)	3.857 ksi
Shear Stresses	Smin(My)	-0.000 ksi
	Saxial	0.161 ksi
	Tx	0.322 ksi
	Ty	2.626 ksi



Figure5: Constructed Racing Go-Kart

Conclusion

Because of the growing involvement, Go-Kart design and construction have gotten more difficult. There are a few things to consider when it comes to engineering automobiles in general. Engineers may use this method to provide the best possible product for society. The chosen design is the safest and most trustworthy for each racing car. Mass Density 281.550 lbmass/ft³ Yield Strength 40.000 ksi Ultimate Tensile Strength 50.000ksi were the results of the Simulation Static Analysis. The design

calculations were completed, and the best outcome was attained. The design criteria take into account ergonomics, safety, ease of manufacture, and dependability. Simultaneously, all factors such as reliability, safety, cost, performance, aesthetics, ergonomics, standard measurements, and material were taken into account. Wherever possible, inventor analysis was used to evaluate the loaded parts, and changes were made as needed to avoid design

References

[1] Babu, Anne Naveen (2013). *Optimization of braking system of a Go kart*. Staffordshire University

[2] Michell S, Rajagopal K, MURTY V S S, Harikrishna V, Design of a go-kart vehicle, *International journal of science, engineering and technology research* 6 (3)

[3] Hajare K, Shet Y, Khot A(2015), Design and Analysis of a Go-Kart Chassis, *International Journal of engineering technology, management and applied science*, 4 (2)

[4] Chiaka Eden, Joseph E. H(2014). Comparative study on Go-kart. Akwa.Green press.

[5] Faieza, A.A S. M. Sapuan, M. K. A. Ariffin, B. T. H. T. Baharudin and E. E. Supeni (2009). Design and fabrication of a student competition based racing car. *Scientific Research and Essay* Vol. 4 (5) pp. 361-366, Available online at <http://www.academicjournals.org/SRE> ISSN 1992-2248. 2009 Academic Journals. Retrieved 6/8/15

[6] "how to design go-kart" www.instructables.com

failure. Because each component is precisely constructed to account for all types of failures and safety dangers so that the produced Go-kart can withstand any adverse condition on the road

Declaration of Conflicting Interests

The author(s) declared no potential conflicts of interest with respect to the research, authorship, and/or publication of this article.

[7] Rimin, Shal, M.S.M, Yusoff, K.A, Hamazh, Z and Hamidon, M.W. (2005). The Go-kart design and construction. SKY-RC team, Technical Report for vehicle Dynamics Module, Malaysia: KUTKM

[8] Ebrahimi-Nejad, S and Kheybari, M (2017). Brake system Design for sport car using Digital logic method. *International Journal of Automotive Engineering*, Vol. 7. No. 4.

[9] Ataur Rahmami and Mohamad Amsyar (2018). Development of a Dc Motor Assisted hydraulic Braking System for Automotive use. *International Journal of Automotive Engineering*, Vol. 8. No. 4, 2672-2678.

[10] Ajami, M, Jannat, H and Masih-Tehrani, M (2020). The Effect of Tire pressure change on Braking efficiency and Necessity of Adjusting tire pressure Before Braking Test at Vehicle Technical Inspection. *International Journal of Automotive Engineering*, Vol. 10. No. 4, 3446-3456.

[11] Khurmi, R.S and Gupta, J.K (2005). A Textbook Of Machine Design. Eurasia publishing house, New Delhi.