

A Full-Cycle 3 Dimensional Numerical Simulation Of a Direct Injection Diesel Engine

S. Jafarmadar^{1,*}, M. Khanbabazadeh²

1. Associated Professor, 2. PhD. Student, Mechanical Engineering Department, Technical Faculty, Urmia University, Iran

* s.jafarmadar@mail.urmia.ac.ir

Abstract

In the present work, multidimensional modeling of open-cycle process of OM355 engine was developed. Calculations for computational mesh were carried out. The results of the model were validated by experimentally measured in-cylinder pressure and the good agreement between calculations and measurements approved the trustworthiness of numerical code. Results included pressure, temperature, emission and rate of heat release diagrams were represented for the full cycle. Furthermore local flow field velocity vectors were indicated. The results show the importance of open-cycle simulations in automotive engine researches.

Keywords: Numerical, Simulation, Diesel, Engine, Full-cycle, Open-cycle, 3 dimensional

1. Introduction

The invention of diesel engine by its great benefits for transportation caused to forming another new problems especially environmental pollution and fuel economy. Many efforts have been made by scientists and engineers to recognize the most effective factors which cause to achieve more efficient engine with the least pollutant production. On the other hand in some cases there was an incompatibility between the methods which was used to reduce pollutant and increase engine performance. So it was very important to establish equilibrium between engine efficiency and pollution or find a parameter which gives a rise in performance with decrease in pollution. One of the most important parameter which has been recognized is the total and local amount of air-fuel mixing and air fuel ratio.

Numerous experimental and numerical studies have been developed to find out the best methods to increase air-fuel mixing and achieve a homogeneous mixture. B. F. Lin and M. Ogura [1] developed a system named NICS-MH to investigate the characteristics of the fuel impinging diffusion, the collision between fuel particles, and the effect of the width on a multi-impingement wall. They found that NICS-MH system improves the BSFC of engine under high speed and full load. Several groups of researchers such as J. Li and et al [2] and Z. Han and

et al [3] focused on the effect of fuel injection mode on the pollutants production. L. Zhang and et al [4] studied the effect of piston head shape on combustion process in their experiments. They pay a special attention on induced swirl resulting from the shape of piston head at TDC and in the course of expansion. They found that the re-entrant piston head could generate the maximum possibility of flame moving and result great smoke reduction.

Nowadays numerical simulations play significant role in engineering investigation. Specially expense and time problems make scientists decided to use numerical codes instead of costly time consuming experimental methods. In the field of diesel engines computational fluid dynamic so-called CFD methods by combustion and species transport models develop a powerful tool to simulate what happen inside the engine [5, 6, 7].

Most of numerical studies namely close-cycle simulation have shown specific favors to in-cylinder flow simulation without considering inlet and outlet flow through intake and exhaust valves [5]. As a result this kind of simulations ignores the effect of valve geometrical parameters on primary swirl and tumble on air-fuel mixing. Because of the effective role of swirl and tumble in air-fuel mixing quality, considering the change of swirl and tumble with modifications in inlet/outlet valves geometrical specifications is unavoidable. Furthermore developing researches about valve timing to approach

homogeneous charge combustion ignition engine demands new kind of numerical analyzing which considers inlet/outlet valves opening/closing. Considering the importance of the recent introduced type of computational fluid dynamics namely open-cycle simulations and lack of researches on this group of studies there is a great potential of work and optimization in this type of numerical analyzing.

Computational fluid dynamics simulations of internal combustion engines intake/exhaust and in-cylinder flows have traditionally focused on prediction of "global" or cylinder-averaged quantities. But recently the importance of the local flow field on prediction of engine performance and emissions has been revealed from experimental [8] and numerical [9] studies. The importance of the local flow fields can be clearer if we know for example:

Two very different engines may have same discharge coefficient.

Different flows may give rise to the same swirl and/or tumble ratios. For example a symmetric, dual valve port which results in two vortices will produce the same swirl ratio as will a single, centrally located low-swirl intake port.

Flow fields having the same cylinder averaged quantities, including temperature, pressure, swirl ratio, etc. can result in significantly different emissions behavior.

Present paper is another effort in direction of the other researchers numerical investigations which focused on simulation of a DI diesel engine with open-cycle procedure and considers local flow field, swirl and tumble at every crank angle. The next goal which will be included in the future works is investigating the possibility of changing present engine to a HCCI engine using IEGR.

2. Model Theoretical Background

2.1 Combustion formulation

The chemistry of ignition has been the subject of numerous studies (Cox, et al [10]; Fisch, et al [11]; Halstead, et al. "A Mathematical Model" [12]; Halstead, et al. "The Auto-ignition" [13]). There is now a general, although not precise, understanding of the hydrocarbon oxidation mechanism at pressure and temperature conditions relevant to compression ignition of diesel fuels.

The reaction mechanism used in this work for simulation of homogeneous charge compression ignition and of diesel fuel self-ignition has been developed along the lines of reaction scheme originally proposed for the study of auto-ignition phenomena in gasoline engines (Halstead, et al. "A

Mathematical Model" [12]); Halstead, et al. "The Auto-ignition" [13]). In this reaction scheme, species that play a similar role in the ignition chemistry are combined and treated as a single entity.

In order to use the reaction mechanism within the framework of a multidimensional computation, reactions related to Propagation have been mass-balanced due to Schäpertöns and Lee.

The adaptation of the kinetic rate parameters to enable application of the model to study self-ignition of diesel fuel follows the lines of Theobald and Cheng.

2.2 NO_x Formulation

The reaction mechanism was expressed in terms of the extended Zeldovich mechanism [14]. In the literature different possibilities are suggested to represent the rate law for NO (Bogensperger [15]; Heywood [16]; Warnatz and Maas [17]).

In the present Combustion Model, an irreversible single-step reaction mechanism is used for the conversion of fuel, involving only stable molecules such as C_nH_m (as fuel), O₂, CO₂, H₂O and N₂. Hence, an approach is implemented based on these stable molecules in order to predict thermal NO.

In addition, the characteristic times (Heywood [16]) for the formation of thermal NO is several orders of magnitude slower than those characteristic times of the combustion process.

2.3 Soot Formulation

The processes of particle formation and surface growth are taken to be related functions of the local fuel and soot nuclei concentration, respectively, and the predominating flame temperature governing the Arrhenius rate coefficient of the particle mass addition term (Tatschl, et al [18]; Tesner, et al [19]).

Since in practical combustion devices, turbulent mixing predominantly influences the overall soot depletion rate, the particle oxidation process actually determines the soot emission level. It is modeled according to a hybrid chemical kinetic/turbulent mixing controlled rate expression, with the net oxidation rate governed by the slower of the two processes.

The soot oxidation source term was expressed Magnussen and Hjertager [20].

2.4 Spray Formulation

The growth of an initial perturbation on a liquid surface is linked to its wavelength and to other

physical and dynamic parameters of the injected fuel and the domain fluid [21]. There are two break-up regimes, one for high velocities and one for low velocity Rayleigh type break-up.

The methods in turbulent dispersion model has been used is stochastic dispersion method which was employed by Gosman and Ioannidis [22]. In this method employed the effects of turbulence on the spray particles are modeled by adding a fluctuating velocity to the mean gas velocity.

The Walljet1 has been used as the interaction model which in principle is based on the spray/wall impingement model of Naber and Reitz (1988) [23]. The concept is that under engine conditions a vapor cushion is formed under the droplets and that they rebound or slide along the walls. Since the wallfilm physics do not play an essential role within the wall interaction process; this model does not take into account the wallfilm physics.

The reflecting normal velocity component is calculated as function of the droplet Weber number just before and just after the impingement using an empirical correlation for the Weber number of the reflected drop. An empirical function has been derived by Wachters and Westerling [24].

For the jet regime, when the Weber number is bigger than a predefined value ($We_C=80$), it is assumed that an incident drop is reflected in the manner similar to how a liquid jet would behave [23]. The droplet reflection velocity in this respect is calculated with the assumption that the magnitude is unchanged, but only the reflection direction varies. The circumferential angle is determined by a probability distribution function, derived assuming a two-dimensional potential flow jet conserving mass and momentum [23].

The droplet diameter after the impingement in both regimes is calculated as a function of Weber number currently distinguishing between the following Weber number criteria.

$$\begin{aligned} We < 50 & \quad d_1 = d_0 \\ 50 \leq We \leq 300 & \quad d_1 = d_0 \cdot f(We_{1-in}) \\ We > 300 & \quad d_1 = 0.2 \cdot d_0 \end{aligned} \quad (1)$$

The reflection angle may vary within $0 < \beta < 5$ degrees.

The droplet heat-up and evaporation process is based on a model originally derived by Dukowicz [25]. Heat and mass transfer coefficients are set-up according to the model physics, but for fine tuning and matching with experimental data, two adjustment parameters (E1, E2) for the heat and mass transfer coefficients are provided for this model.

In the evaporation model of Dukowicz [25] it is considered that the droplet is evaporating in a non-condensable gas. So it uses a two-component system in the gas-phase, composed of the vapor and the non-condensable gas, even though each component may consist of a mixture of different species.

For spherical droplets the heat flux can be obtained from heat transfer coefficient correlations. The Nusselt number Nu is obtained from the following correlation proposed by Ranz and Marshall [26] for single droplets and confirmed to apply to certain types of sprays by Bose and Pei [27]

$$Nu = 2 + 0.6Re^{1/2}Pr^{1/3} \quad (2)$$

3. Numerical Model Description

The numerical models used are based on standard hydrocarbon auto-ignition mechanism combustion model developed by Cox, et al [10]; Fisch, et al [11]; Halstead, et al [13] for the simulation of gas/wall heat transfer, high temperature combustion, species transport, ignition, turbulent combustion, and pollutant formation of hydrocarbon fuel, air, and residual (exhaust) gas as discussed previously. Eddy Breakup model was developed as the combustion model with active turbulence controlled combustion model (based on Magnussen formulation). The reaction time scale in this model considered to calculate with by the local value of the ratio of the turbulence kinetic energy k and its dissipation rate \mathcal{E} . Zeldovich model was used as NO model and Kennedy-Hyroyasu-Magnussen as soot formation model.

The sub models for spray breakup, ignition and combustion used in this study are those discussed in the work of Liu, A.B. and Reitz, R.D [21]. These models were applied to simulate single and multiple injection combustion diesel engines under a wide range of operating conditions and good agreement between predictions and measurements were obtained [22]. Wall interaction sub model in mentioned model considered as Walljet1. For the spray breakup model Wave model was applied.

The k- ϵ model is the most widely used turbulence model, particularly for industrial computations and has been implemented into most CFD codes. It is generally accepted that the k- ϵ model usually yields reasonably realistic predictions of major mean-flow features in most situations. Hence k- ϵ model was used in this study as the turbulence model because of more realistic flame structures.

scalar multiplication of the transport equation for the velocity fluctuation Du / Dt by the velocity fluctuation itself u:

$$\rho \frac{Dk}{Dt} \equiv \underbrace{\rho \frac{\partial k}{\partial t}}_L + \underbrace{\rho U_j \frac{\partial k}{\partial x_j}}_C = \underbrace{\rho f_i u_i}_{\rho P} - \underbrace{\rho u_i u_j \frac{\partial U_i}{\partial x_j}}_{\rho P} - \underbrace{\mu \left(\frac{\partial u_i}{\partial x_j} \right)^2}_{\rho \epsilon} + \underbrace{\frac{\partial}{\partial x_j} \left(\mu \frac{\partial k}{\partial x_j} - \rho \overline{k u_j} - \overline{\rho u_i \delta_{ij}} \right)}_D \tag{3}$$

Equation $\rho Dk/Dt$ describes the dynamics (and a budget) of the turbulent kinetic energy, where the terms have the following physical meanings: L - local change in time, C - convective transport, P - production of k (“of turbulence”) by mean-flow deformation (work of turbulent stresses associated with the mean flow deformation, or transfer of the energy from the mean motion to the turbulent

The k-ε model consists of the transport equations for k and for ε. The exact k equation is derived by fluctuations by the action of Reynolds stresses), note

that usually $\overline{u_i u_j} > 0$ when $\partial U_i / \partial x_j > 0$ so that in most flows $P > 0$; G is the production (or destruction) of k by body force; ε - dissipation of k into heat by the action of viscosity (Note $\epsilon > 0$ always); D - diffusive transport of k (viscous, by fluctuating velocity and by fluctuating pressure, respectively).

Computational mesh which is developed by AVL FIRE V8.3 represents whole parts of OM355 engine combustion chamber, intake and exhaust port with valves which geometrical characteristics can be obtained from Table. 1. The fuel injector has four injection holes with 3.1mm diameter and injection rate scheme is same as Fig. 1.

The computational mesh based on inlet/outlet valves states is involved in 5 steps transforming when it moves from 0° CA to 720° CA as below:

Table. 1. Characteristics of OM355 Engine

piston course = 150.0 mm	Intake valve diameter = 42.0 mm
Rod length = 280.0 mm	Exhaust valve diameter = 37
Compression ratio: 16:1	Intake port diameter = 37 mm
Volume clearance with combustion chamber = 127.165 cm3	Exhaust port diameter = 32 mm
Engine speed = 1400 rpm	Valves trace on piston head = 0.1mm
Injector spray angle between piston head axes and nozzle hole axes(degree) = 70°	Inlet area = 0.0010752 m2
Combustion chamber shape: Cylindrical	Outlet area = 0.000804247 m2
Initial pressure = 1 bar	Injection Pressure = 195 atm
Initial temperature = 301 K	Injection time: 18° BTDC
Inlet air temperature = 301 K	IV open: 30° BTDC / IV close: 120° BTDC
Fuel type: Standard diesel fuel	EV open: 60° BTDC / EV close: 25° ATDC
Injection fuel temperature = 353 K	

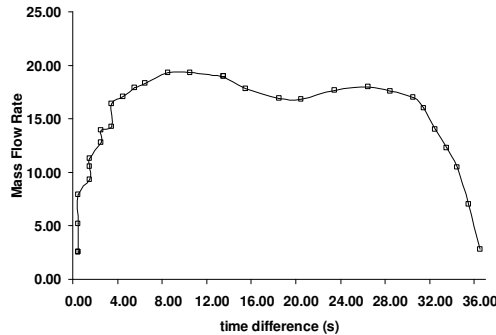

Fig1. Fuel Injection Scheme of OM355 Engine

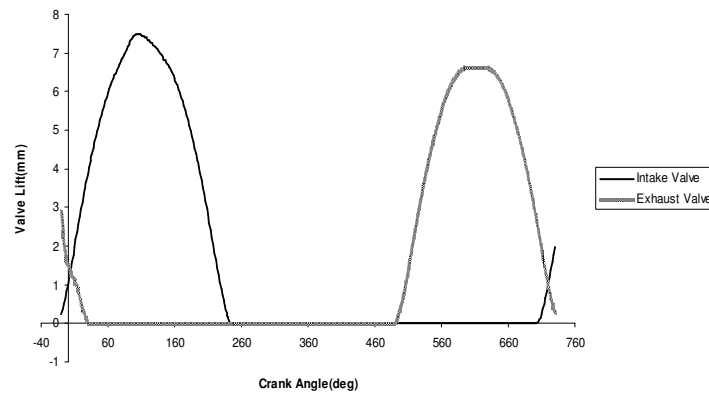

Fig2. Intake and Exhaust Valves Curve of OM355 Engine

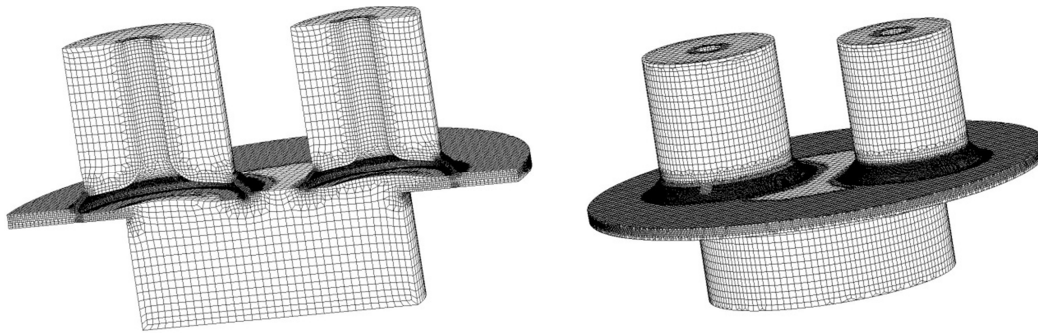

Fig3. Computational Domain for Overlapping Stage

3.1. Overlapping Stage

As the Fig. 2. Intake and exhaust valves have an overlapping period between 0° CA to 25° CA and 690° CA to 720° CA. this step of simulation is the most critical one. Because simultaneously opening of intake valve and closing of exhaust valve and moving of piston force an intense deforming to computational mesh. So the mesh resolution should be adequately especially near the valves seat area during this period to avoid any negative volume forming. Fig.3. Graphically represents the computational mesh of overlapping stage.

3.2. Exhaust Valve Closed Stage

This stage includes all meshes between 25° CA to 240° CA while exhaust port and exhaust valve have not been considered in computational mesh as Fig. 4. Shows.

3.3. Exhaust and Intake Valves Closed Stage

Compression and combustion strokes of OM355 engine is between 240° CA to 480° CA while both intake and exhaust valves are closed as Fig. 5. Represents.

3.4. Exhaust Valve opened stage

Discharging stroke starts at 480° CA by exhaust valve opening and continues to 690° CA when the other valve starts to open. Fig. 6.

The number of cells of computational mesh varies from 193479 cells to 654981 cells. All computation is carried out at 1400 rpm and full load case (at the worst operation point the view of emission). Meshing process left 41 hours. Calculations left 76.5 hours.

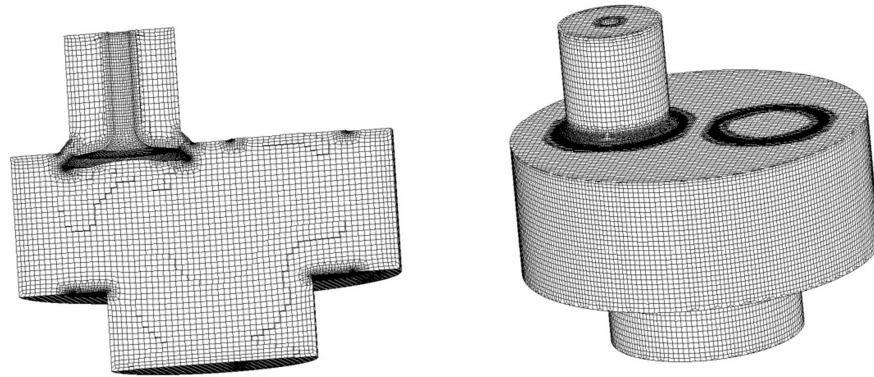

Fig4. Computational Domain for Exhaust Valve Closed Stage

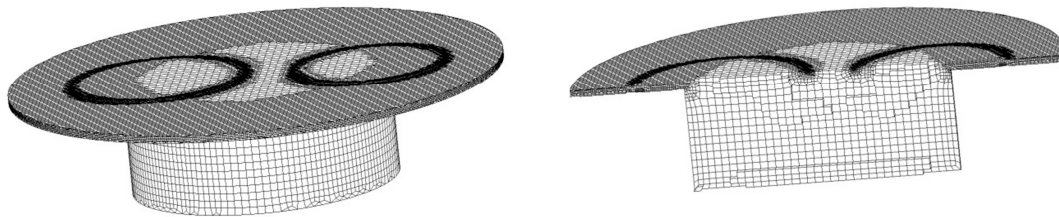

Fig5. Computational Domain for Exhaust Valve Closed Stage

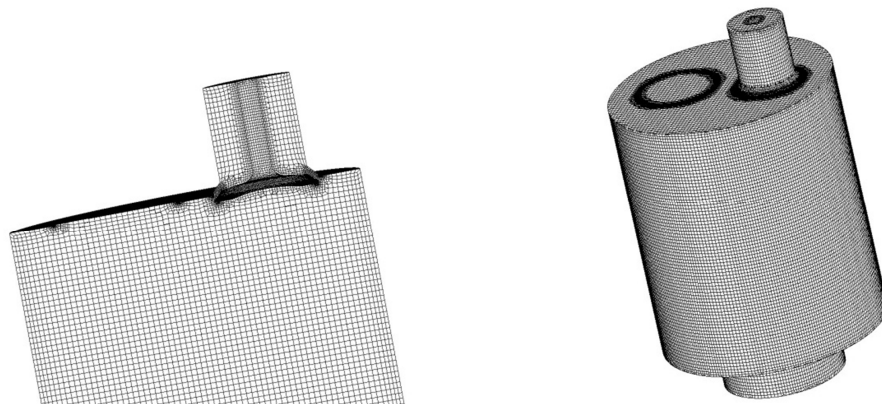

Fig6. Computational Domain for Exhaust Valve Closed Stage

4. Experimental Methodology and Validation

The numerical calculations have been validated with the experimental data obtained by V. Pirouzpanah, et al [28]. Experimental measurements of in-cylinder pressure of OM355 engine equipped with the same combustion chamber and

intake/exhaust valves were obtained in different crank angles. Comparing between calculated and experimentally measured in-cylinder pressure from Fig. 7. Shows a good agreement so it is approved that numerical calculations developed in this study are trustworthy.

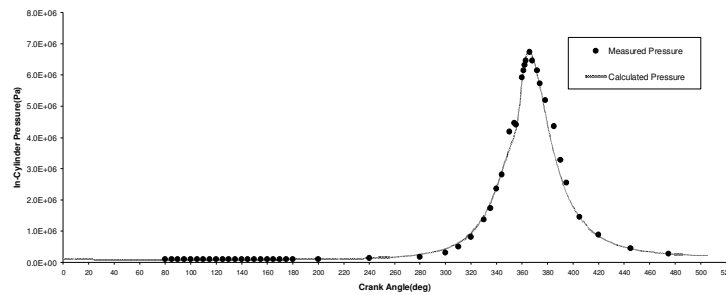

Fig7. Numerically Calculated and Experimentally Measured In-Cylinder Pressure

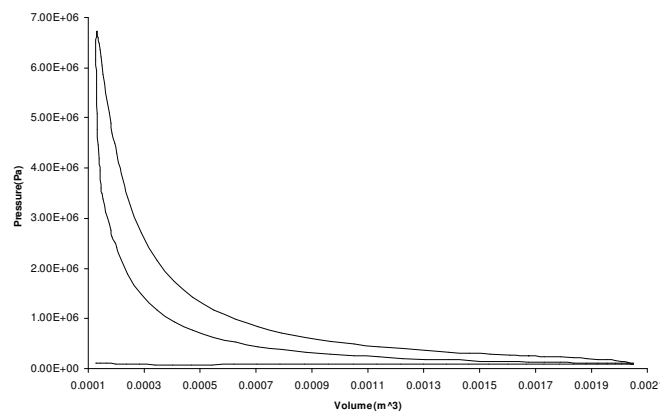

Fig8. In-Cylinder Pressure – Volume Diagram

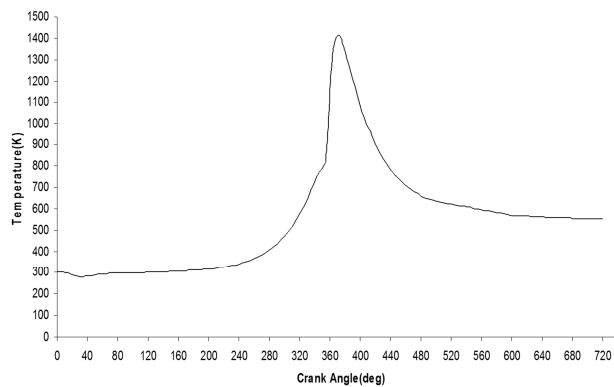

Fig9. Calculated Temperature – Crank Angle Diagram

5. Results and Discussion

As the previously described computational mesh was calculated from 0° CA to 720° CA the results are as below.

Fig. 8. and Fig. 9. Show pressure-volume, in-cylinder temperature variation diagram respectively.

Heat release rate data are presented in Fig. 11. Considering the combustion process to proceed in two phase, namely premixed and diffusion, is clear at this figure.

Fig.10 indicates the predicted soot and NOx emissions variation with crank angle. It is clear that the general trends of reduction in NOx and increase in soot can be observed (trade- off soot and NOx). On

the whole, it can be seen that the area which the equivalence ratio is close to 1, the temperature is higher than 2000 K and the O₂ is available, is the NO_x formation area. In addition, the area which the equivalence ratio is higher than 3 and the temperature is approximately between 1000 K and 1500 K is the Soot formation area. Also there are two factors that

control the soot oxidation: temperature and availability oxidizer (air). Therefore, the mass fraction of soot emission strongly associated with O₂ mass fraction or accurately equivalent Fuel/Air ratio and local temperature. In other word where Fuel/Air ratio and local temperature is low, the probability of soot formation increases. Fig. 12 confirms this fact.

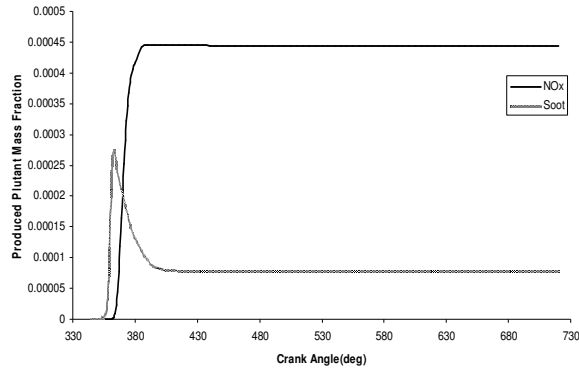

Fig10.NOx and Soot Mass Fraction-Crank Angle Diagram

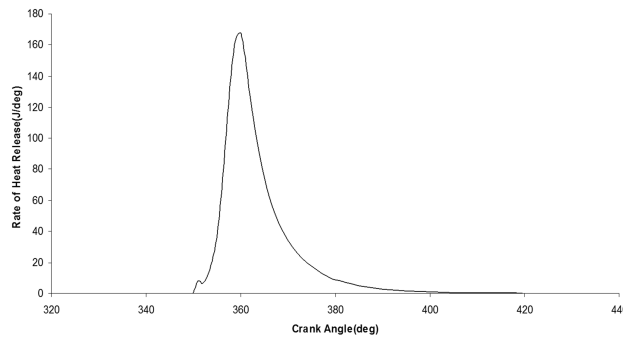

Fig11.Heat Release Rate Diagram-Crank Angle Diagram

The most effective plan to reduce soot and NO_x mass fraction simultaneously is two increase air/fuel ratio specially where the droplets of spray cloud have large diameter. To reach this purpose the local flow fields should have enough energy to break up the fuel droplets and to have the ability of transportation of air to lean zones. The main parameter which is involved in this case is the primary swirl and local flow field velocity. The high amount of swirl ratio leads to proper air/fuel ratio and less pollutant production. Fig. 13. to Fig. 15. Indicate local flow field's velocity at different crank angles.

The other important parameter to discuss is the flame velocity and flame distribution in chamber. It is well known that for further smoke reduction, it is

important to achieve fast flame motion during diffusion combustion and desirable fuel/flame distribution inside and outside the chamber simultaneously. Fig.16 indicates flame distribution and soot mass fraction contours for all models at four position of piston and completely confirms this conclusion.

A look again at Fig. 16. Reveals that generally soot production of engine at piston squish area is low. Reason is hidden in this fact that if larger flame/fuel spread over narrow clearance in the squish region at earlier time when the piston is near the TDC, the cooling effect of the wall and weak air tumble and swirl occur in the cylinder(induced swirl). In other word after combustion, weak swirl in this region will

cause large soot formation and poor oxidation of the formed soot. In addition, swirling motion of gas phase plays an important role in mixing process between fuel and air, and between partially oxidized product (soot) and air. When there exists a high swirling motion, liquid fuel and fuel vapour (with higher density than the ambient gases) in the core region of

sprays tend to move from inner region to outer region where fresh air is available (centrifugal-forced-induced-stratification). In contrast, the hot (low density) combustion products move towards the inner region. Thus, it is expected that the induced secondary mixing due swirl motion might enhance soot oxidation.

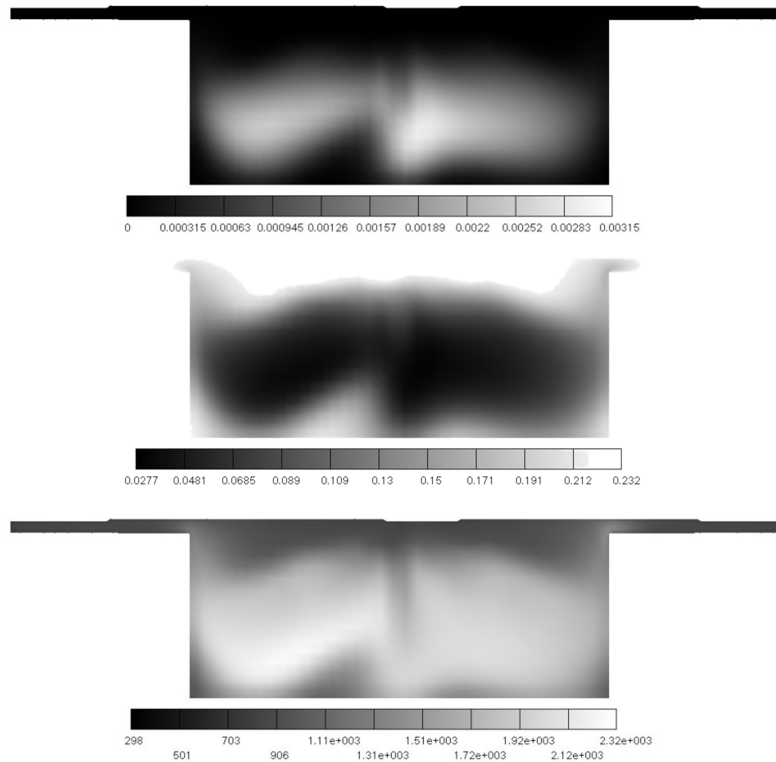

Fig12. Contours of soot mass fraction, O₂ mass fraction and temperature (K) at 360° CA respectively from top

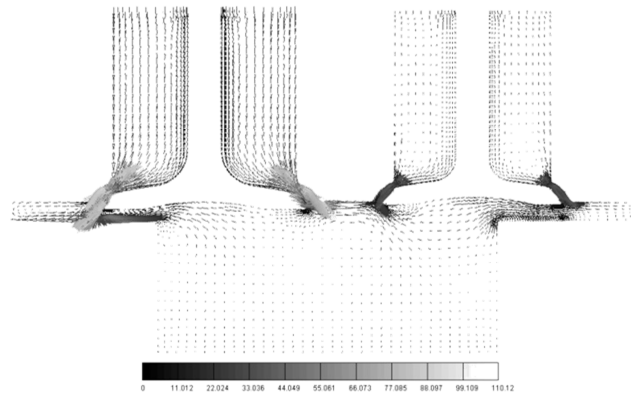

Fig13. Velocity vectors of computational domain at 375° CA

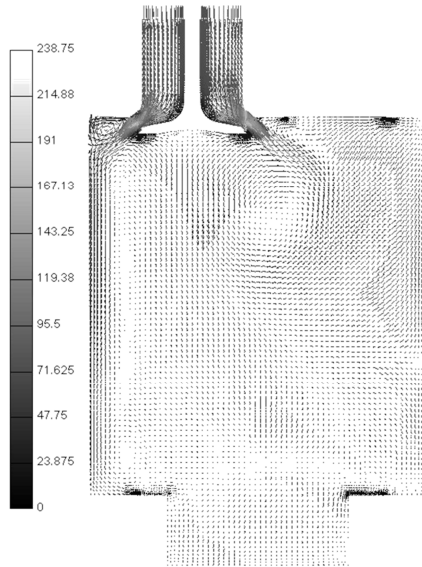

Fig14. Velocity vectors of computational domain at 150° CA

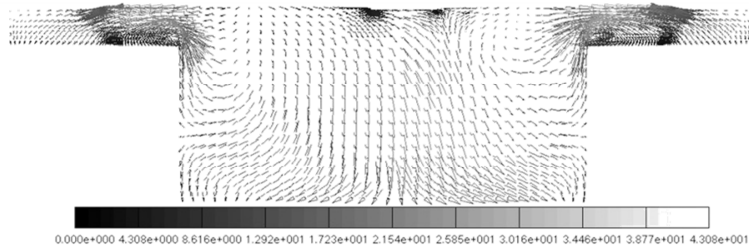

Fig15. Velocity vectors of computational domain at 375° CA

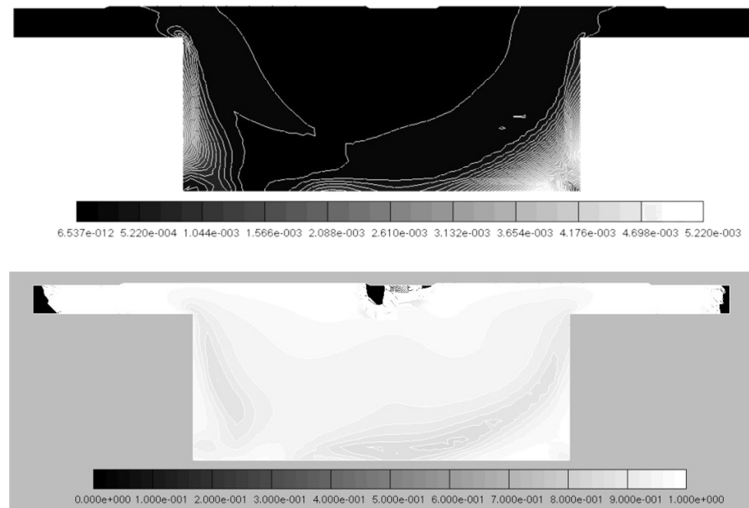

Fig16. Contours of soot mass fraction and flame at 375° CA respectively from top

Conclusion

The full-cycle calculations of the OM355 engine were carried out. This study revealed the importance of open-

cycle numerical simulations which presents wide range of information about flow field engine. Furthermore the role of swirl and local flow field velocity on the reduction of emissions was discussed. In general this study shows the importance of open-cycle simulations in the future researches specially in the branch of HCCI engines simulation.

References

- [1]. B. F. Lin, M. Ogura. A New Multi-Impingement-Wall Head Diffusion Combustion System (NICS-MH) of a DI Diesel Engine – The Effect of Combustion Chamber Geometry. SAE 951792, 1995.
- [2]. J. Li, J. O. Chae, S. M. Lee, J. S. Jeong. Modelling The Effect of Split Injection Scheme on Soot and NO Emissions of Direct Injection Diesel Engines by a Phenomenological Combustion Model. SAE 962062, 1996.
- [3]. Z. Han, A. Uludogan, G. J. Hampson, R. D. Reitz. Mechanism of Soot and NO_x Emission Reduction Using Multiple-Injection in a Diesel Engine. SAE 960633, 1996.
- [4]. L. Zhang, T. Ueda, T. Takatsuki, K. Yokota. A Study of the Effect of Chamber Geometries on Flame Behaviour in a DI Diesel Engine. SAE 952515, 1995.
- [5]. F. Payri, J. Benajes, X. Margot, A. Gil. CFD Modelling of the In-Cylinder Flow in Direct-Injection Diesel Engines. Elsevier, J Computers & Fluids, 33 (2004) 995-1021.
- [6]. L. M. Mesaros, P. W. Stephenson. Application of Computational Mesh Optimization Techniques to Heavy Duty Diesel Intake Port Modelling. SAE 1991-01-1182, 1999
- [7]. A. A. Amsden. KIVA-3: A Block-Structured KIVA Program for Engines with Vertical or Canted Valves. Los Alamos Report LA-11560-MS, 1997.
- [8]. Y. Iwamoto, K. Noma, O. Nakayama, T. Yamauchi, H. Ando. Development of Gasoline Direct Injection Engine. SAE 970541, 1997.
- [9]. T. Kume, Y. Iwamoto, K. Iida, N. Murakami, K. Akishino, H. Ando. Combustion Control Technologies for Direct Injection SI Engine. SAE 960600, 1996.
- [10]. R. Cox, and J. Cole, Chemical Aspects of the Auto ignition of Hydrocarbon-Air Mixtures.
- [11]. A. Fisch, A. Read, W. Affleck, W. Haskell. The Controlling Role of Cool Flames in Two-Stage Ignition. Combustion Flame 13 (1969): 39-49.
- [12]. M. Halstead, L. Kirsch, A. Prothero, O. Quinn. A Mathematical Model for Hydrocarbon Auto-Ignition at High Pressures. Proc. Royal Society of London, A246, 1975: 515-538.
- [13]. M. Halstead, L. Kirsch, C. Quinn. The Autoignition of Hydrocarbon Fuel at High Temperatures and Pressures - Fitting of A Mathematical Model. Combustion Flame 30 (1977): 45-60.
- [14]. Y. B. Zeldovich, P. Y. Sadovnikov, D. A. Frank-Kamenetskii. Oxidation of Nitrogen in Combustion. Translation by M. Shelef, Academy of Sciences of USSR, Institute of Chemical Physics, Moscow-Leningrad, 1947.
- [15]. M. Bogensperger. A Comparative Study of Different Calculation Approaches for the Numerical Simulation of Thermal NO Formation. Diss. U. Graz, 1996.
- [16]. J. B. Heywood. Internal Combustion Engine Fundamentals. McGraw-Hill Book Company, Second Series, 1988.
- [17]. J. Warnatz and U. Maas. Technische Verbrennung, Physikalisch-Chemische Grundlagen, Modelbildung, chadstoffentstehung. Springer Verlag Berlin Heidelberg, 1993.
- [18]. R. Tatschl, K. Pachler, H. Fuchs, and W. Almer. Multidimensional Simulation of Diesel Engine Combustion - Modeling and Experimental Verification. Proceedings of the Fifth Conference 'The Working Process of the Internal Combustion Engine'. Graz, Austria, 1995.
- [19]. P.A. Tesner, T.D. Snegriova, V.G. Knorre. Kinetics of Dispersed Carbon Formation. Combustion and Flame 17 (1971): 253-260.
- [20]. B.F. Magnussen, B.H. Hjertager. On mathematical modeling of turbulent combustion with special emphasis on soot formation and combustion. Sixteenth International Symposium on Combustion. Pittsburgh: The Combustion Institute, 1977.
- [21]. A.B. Liu, R.D. Reitz. Modeling the Effects of Drop Drag and Break-up on Fuel Sprays, SAE 930072, 1993.
- [22]. A.D. Gosman, E. Ioannides. Aspects of Computer Simulation of Liquid-Fueled Combustors. AIAA, 81-323, 1981.
- [23]. J.D. Naber, R.D. Reitz. Modeling Engine Spray/Wall Impingement. SAE- 880107.
- [24]. L.H.J. Wachters, N.A.J. Westerling. The Heat Transfer from a hot Wall to Impinging Water Drops in Spheroidal State. Chem. Eng. Sci., 21 (1966), pp.737- 743
- [25]. J.K. Dukowicz. Quasi-steady droplet change in the presence of convection, informal report Los Alamos Scientific Laboratory. LA7997-MS.
- [26]. W. E. Ranz, W. R. Marshall. Evaporation from Drops. Chem. Eng. Prog. 48, 141-146, 173-180, 1952.
- [27]. A. K. Bose, C. T. Pei. Evaporation Rates in Spray Drying. Can. J. Chem., 42, 252, 1964.
- [28]. V. Pirouzpanah, et al, "Reduction of Pollutants Emissions of OM355 Diesel Engine to Euro2 by Converting to Dual Fuel Engine (Diesel+Gas)." Proceeding of first Conference of Automotive Fuel to CNG, 19-20 Jun 2003, Tehran, Iran, pp84-94