

Thermo-mechanical analysis of diesel engines cylinder heads using a two-layer viscoelasticity model with considering viscosity effects

H.Ashouri¹

¹Sama technical and vocational training college, Islamic Azad University, Varamin Branch, Varamin, Iran

Abstract

Loading conditions and complex geometry have led the cylinder heads to become the most challenging parts of diesel engines. One of the most important durability problems in diesel engines is due to the cracks valves bridge area. The purpose of this study is a thermo-mechanical analysis of cylinder heads of diesel engines using a two-layer viscoelasticity model. The results of the thermo-mechanical analysis indicated that the maximum temperature and stress occurred in the valves bridge. The results of the finite element analysis correspond with the experimental tests, carried out by researchers, and illustrated the cylinder heads cracked in this region. The results of the thermo-mechanical analysis showed that when the engine is running the stress in the region is compressive caused by the thermal loading and combustion pressure. When the engine shut off the compressive stress turned into the tensile stress because of assembly loads. The valves bridge was under the cyclic tensile and compressive stress and then is under low cycle fatigue. After several cycles the fatigue cracks will appear in this region. The lifetime of this part can be determined through finite element analysis instead of experimental tests. Viscous strain was more than the plastic strain which is not negligible.

Keywords: thermo-mechanical fatigue, finite element analysis, cylinder heads and Valves Bridge

1. Introduction

Cylinder heads are the important parts of the internal combustion engines which are under thermo-mechanical stresses for the sake of their working type [1-10]. Therefore, selection of materials is of paramount importance since they must have sufficient mechanical strength at high temperatures to be able to withstand cyclic stresses caused by heat and pressure [2, 9, 11].

High output capacity, low fuel consumption, low emission and reducing the cost of maintenance are among the restrictions making the design of cylinder heads a complicated task [4, 12]. Thus, detailed analysis and design are essential. Escalation in environmental concerns and fuel costs underlines the need for research on more efficient engines with less energy dissipation and emission [2, 12]. One way to decrease the fuel costs is to reduce the weight of vehicles. Hence, lighter alloys must be used in pursuit of this goal [2, 9]. Recently, the use of aluminum alloys has increased for economic reasons and for improvement of engine power by weight reduction.

Aluminum-Silicon is a casting alloy which has extensive use in the automotive industry, especially in cylinder heads of diesel engines. These materials have been replaced by a variety of cast iron which were previously used in the manufacture of cylinder heads [2]. Thermal deformation is the greatest challenge faced by the aluminum cylinder heads [13].

Cylinder heads are exposed to thermal and mechanical loads. The temperature difference, which is the result of turning the engine on and off, begets thermo-mechanical fatigue (TMF) loads on the cylinder heads [2, 4, 12, 14, 15, 16] and consequently reduces their lifetime, especially in thinner regions [17]. The crucial regions include the valves bridge and areas near spark plugs and injectors [3, 18, 19]. Cylinder heads endure out-of-phase TMF. Namely, the maximum stress occurs at the minimum temperature and the minimum stress occurs at the maximum temperature. When the engine shuts off and the temperature is low, the tensile stresses arising from assembly loads will be applied to cylinder heads. As the engine starts and temperature increases the compressive stresses produced by thermal loading

(σ_{th}) and combustion pressure (σ_p) will be applied to them [2, 4]. This type of loading is displayed in Figure 1. As the figure reveals the changes in stress caused by thermal load is very high. The fluctuating stresses come out of the engine which is been heated and cooled [12, 20, 21].

Plastic deformation is observed in structures like cylinder heads which bear high temperature fluctuations and assembly loads. Classical models are used to obtain steady response of these structures. This approach is very expensive. Because many loading cycles are required to obtain a steady response. Cyclic analysis is used in order to avoid the cost of transient analysis [9].

Numerous papers have been presented on analysis of stress and fatigue in cylinder heads. Koch et al. measured experimentally strain of cylinder heads and compared with simulated results using a nonlinear isotropic/kinematic hardening model. A slight difference between the experimental and simulated strain was observed from 55°C to 120°C. The simulated strain by increasing temperature from 110°C to 210°C was estimated more than the experimental strain due to plastic deformation of the cylinder heads [22]. Takahashi et al. examined creep in aluminum cylinder heads. There is concordance between experimental and calculated strain. Creep strain increases as stress grows. Creep strain at 250°C significantly was higher than creep strain at 100°C and 175°C [13].

TMF of cylinder heads was studied by Thomas et al. using the energy model and elasto-viscoplastic law. Their research proved a good agreement between experimental and simulated results of the fatigue life of the cylinder heads and the location of crack initiation [15, 16]. Thermo-mechanical analysis of cylinder heads and cylinders of AFV diesel engines was conducted by Venkateswaran and colleagues. Their research demonstrates that the cylinder heads and engine blocks can tolerate more stress caused by pressure and thermal loads increase [23].

Su et al. predicted fatigue life of cylinder heads by finite element simulation via the model of damage total (Sehitoglu damage model) and compared with experimental results. Their research revealed that the difference between experimental and simulated results is less than 30% [6]. Zieher and colleagues simulated the complete process of lifetime. They used energy model to predict the fatigue life of cast iron cylinder heads. Their research shows the simulated results of the number of cycles of crack initiation and the location of crack initiation are in accord with experimental results [19]. The analysis of high/low cycle fatigue of cylinder heads was performed by Ghasemi using the thermo-mechanical analysis

results. His study verified that the cracks observed in the experimental test of low-cycle of cylinder heads acknowledged the simulated results of low-cycle fatigue. The simulated results of low-cycle fatigue of cylinder heads after modification of cooling systems indicates that high levels of damage parameters do not observe [24].

Shoja'efard et al. experimentally measured the stress in cylinder heads and compared with simulated results. Their research confirmed the concordance between the experimental and simulated results at low temperature. The simulated stress at temperatures exceeding 200°C was estimated to be greater than the experimental stress by reason of the inelastic material deformation [18]. Prediction of the fatigue life of cylinder heads of two-stroke linear engines was done by Rahman and colleagues using finite element analysis (FEA) and stress-life approach. Their research refuted the possibility of failure in all spots [25].

Gocmez and Pischinger investigated the sophisticated interaction effects of thermal and mechanical loads, geometry of cylinder heads and TMF behavior of cylinder heads material. They optimized the valves bridge based on the ratio of mechanical to thermal strain. Their research indicates that the vertical temperature gradients are mainly determined by the thickness of the valves bridge which plays a role in distribution of temperature [3]. Thalmer et al. established the TMF/computer aided engineering (CAE) process for the fatigue assessment of cylinder heads. Their research proved an acceptable agreement between experimental and simulated results of the fatigue life of the cylinder heads [7]. Mirslim and colleagues calculated low-cycle fatigue life by simulation of finite element of cylinder heads based on various criteria of strain based. Their experiments show by cutting the valves bridge we can increase the fatigue life of cylinder heads [12].

Trampr and colleagues studied the effects of thermo-mechanical loads on cylinder heads. Their research indicated concordance between experimental and simulated results of the fatigue life of cylinder heads. Crucial locations in the analysis of fatigue were the same locations of crack initiation in the experimental conditions [8].

Zahedi and Azadi compared the stress and low-cycle fatigue life of aluminum and magnesium cylinder heads of diesel engines. Their research showed that the strain in magnesium cylinder heads was more in comparison with the aluminum ones, while the magnesium cylinder heads had less stress. The fatigue life of the both cylinder heads was almost identical [9]. Azadi and colleagues analyzed cracked

cylinder heads of gasoline engines. Examining materials and doing finite element analysis of cracked cylinder heads stress, they determined the cause of cracks and provided some solutions. Their research revealed that the main reason for cracks initiation in cylinder heads is high stress and plastic strain caused by assembly loads of cylinder heads bolts [1].

TMF analysis of gray cast iron cylinder heads was conducted by Li et al. An acceptable agreement between experimental and simulated results of TMF life was proved[4]. Xuyang and colleagues predicted TMF life of diesel engines cylinder heads. Their research revealed that the discrepancy between experimental and simulated results is 3%[10]. Metzger et al. predicted the lifetime of cast iron cylinder heads under thermo-mechanical loads and high-cycle fatigue. According to their study the experimental and simulated results of temperature match[5].

Aluminum cylinder heads must be adequately robust to tolerate gas pressure, assembly loads and high temperature resulting from ignition to avoid cracking the valves bridge [11]. Thermo-mechanical loading cylinder heads can only be controlled through modern cooling systems or protective coatings such as thermal barrier coating (TBC) that reduces heat

stress and thereby reduces the temperature gradient [26]. Azadi and colleagues studied the impact of TBC on cylinder heads. The results of their research demonstrated the TBC reduced the temperature gradient and consequently the thermal stress reduced. Ergo, fatigue life of cylinder heads augmented [27, 28, 29 and 30].

According to the introduction, due to the lack of information on the behavior of hardening, softening and viscosity of materials the analysis of cylinder heads is mostly based on simple models of material behavior like elastic-plastic and the effects of viscosity and creep of cylinder heads are less taken into consideration. Aluminum alloy has creep behavior at about 300°C and viscosity should also be taken into account [6, 15, 16, 22]. The main objective of this study was to simulate the thermo-mechanical behavior of cylinder heads based on the two-layer viscoelasticity model. In some analyses, it is assumed that temperature changes have no effect on the stress-strain curves and thermo-mechanical analysis of cylinder heads is non-coupled. Since changes in temperature influence on stress-strain curves, the thermo-mechanical analysis of cylinder heads in this study is coupled.

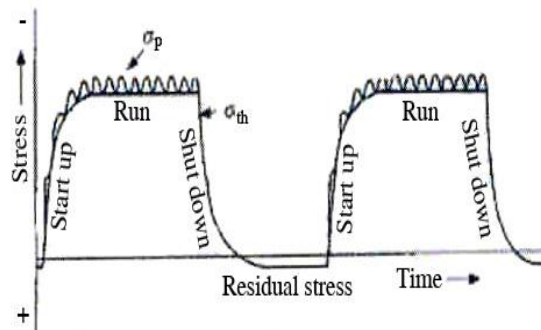

Fig1. The cyclic loading of cylinder head [20].

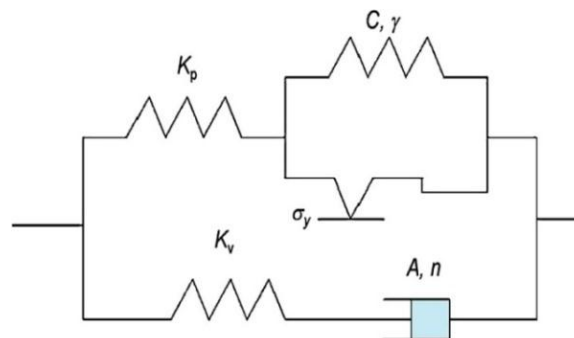

Fig2. The two-layer viscoelasticity model [32].

2. The material and its behavioral model

In this study the cast alloy of aluminum-silicon-magnesium has been used to simulate the thermo-mechanical behavior. The alloy is known as A356.0 or AlSi7Mg0.3 which is applied in diesel engines cylinder heads [14, 28, 29, 30]. The chemical composition of the A356.0 is 7.06 wt.% Si, 0.37 wt.% Mg, 0.15 wt.% Fe, 0.01 wt.% Cu, 0.02 wt.% Mn, 0.13 wt.% Ti, and Al remainder [14].

The two-layer viscoelasticity model divides the elastic and viscosity effects into two elastic-viscous and elastic-plastic networks. As displayed in Figure 2, this model is presented by Kichenin [31]. This model makes the cyclic stress-strain behavior of the material predictable with reasonable accuracy [32].

This model consists of a network of elastic-plastic parallel to a network of elastic-viscous. Plastic deformation and creep can be seen in structures such as cylinder heads of engines which are under assembly loads and temperature fluctuations. The two-layer viscoplasticity model is the best to examine the response of materials such as aluminum cylinder heads which have remarkable dependent behavior on temperature and plastic at high temperatures [5, 7, 9, 14, 32]. This model is in good agreement with results of experimental and thermo-mechanical test of A356.0 alloy [14]. The material behavior of different Aluminum-Silicon casting alloys was described by the nonlinear kinematic/isotropic hardening model of Abaqus software [22].

In the plastic network nonlinear kinematic/isotropic hardening model is applied which predicts the behaviors such as hardening, softening, creep and mean stress relaxation and it is a suitable model for the plastic behavior of materials [14, 32].

Kinematic hardening has both linear and nonlinear isotropic/kinematic model. The first model can be used with Mises or Hill yield surface while the second one can only be used with the Mises yield surface and it is the most accurate and comprehensive model to examine some issues with cyclic loading including cylinder heads of engines. The kinematic hardening model assumes that the yield surface, proportional to the value of α , moves as back stress in yield zone but it does not deform [33]. Abaqus software uses ziegler linear model [33] to simulate this model as following equation shows:

$$\dot{\alpha} = C \frac{1}{\sigma_0} (\sigma_{ij} - \alpha_{ij}) \dot{\epsilon}^{PL} + \frac{1}{C} \dot{C} \alpha_{ij} \quad (1)$$

Where C is kinematic hardening modulus, \dot{C} is of exchange rate of C in temperature and $\dot{\epsilon}^{PL}$ is the rate of equivalent plastic strain. In this model σ^0 (the size of the yield surface) remains constant. In other words, σ^0 is always equal to σ_0 (that is yield stress in zero

plastic strain) remain constant. Nonlinear isotropic/kinematic hardening model includes motion of yield surface proportional to the value of α in stress zone and also changes in the size of yield surface is proportional to the plastic strain [33]. This model has been extracted from Chaboche experience [34, 35]. In order to introduce this model a nonlinear term is added to equation (1) to indicate the size of yield surface [33].

The Abaqus software uses nonlinear isotropic/kinematic hardening model as following equation shows:

$$\dot{\alpha} = C \frac{1}{\sigma_0} (\sigma_{ij} - \alpha_{ij}) \dot{\epsilon}^{PL} - \gamma_{ij} \dot{\epsilon}^{PL} + \frac{1}{C} \dot{C} \alpha_{ij} \quad (2)$$

Where C and γ are material constants. In order to introduce this model in Abaqus software the isotropic and the kinematics parts are required to be defined separately [14]. In order to define the isotropic part the equation (3) is used in which b and Q_∞ are material constants [32]:

$$\sigma^0 = \sigma_0 + Q_\infty (1 - \exp(-b \dot{\epsilon}^{PL})) \quad (3)$$

The overall back stress is computed from the relation (4) [33]:

$$\alpha = \sum_{K=1}^N \alpha_K \quad (4)$$

In equation (4) if we consider N equal to 3, the hardening variable is divided into three parts which increases the accuracy of the model [14].

Norton-Hoff law is used viscous network in order to consider the effect of strain rate, the equation of which is the following [36]:

$$\dot{\epsilon}_V = A (\sigma_V)^n \quad (5)$$

Where the $\dot{\epsilon}_V$ is viscous strain rate, A and n are material constants and σ_V is the viscous stress.

According to equation (6) the rate of the elastic modules in the two viscous and plastic networks is express by f . Where k_v and k_p are elastic modules in the elastic-viscous and elastic-plastic networks respectively [32].

$$f = \frac{k_v}{k_v + k_p} \quad (6)$$

3. The finite element model and material properties

Traditionally, optimization of engine components such as cylinder heads was based on building a series of physical prototypes, and performing a series of different experiments and tests. Unfortunately, this method is time consuming and building a prototype in the early stages of the design is arduous. Many samples must be constructed and tested in order to achieve the precise design. This process is costly.

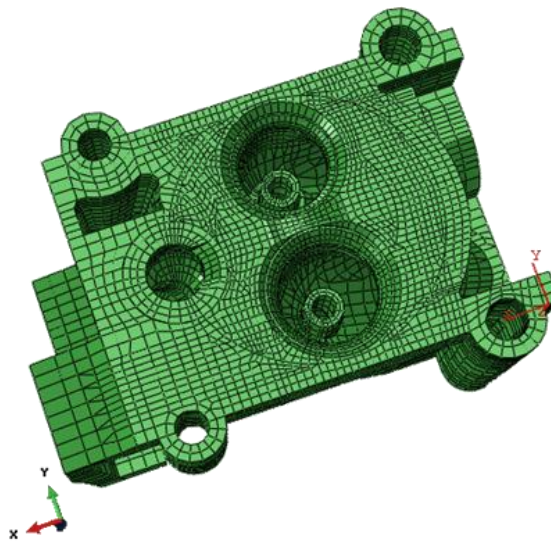

Fig3. The meshed cylinder head [38].

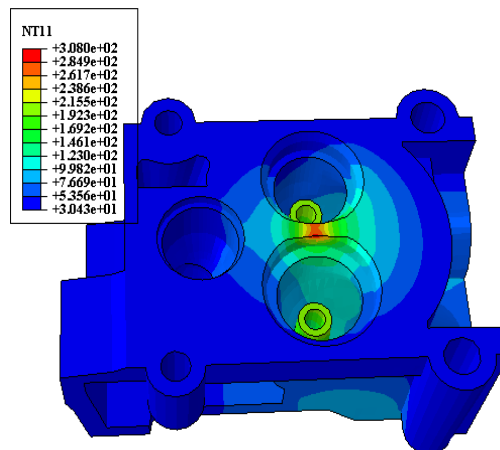

Fig4. The temperature distribution in the cylinder head

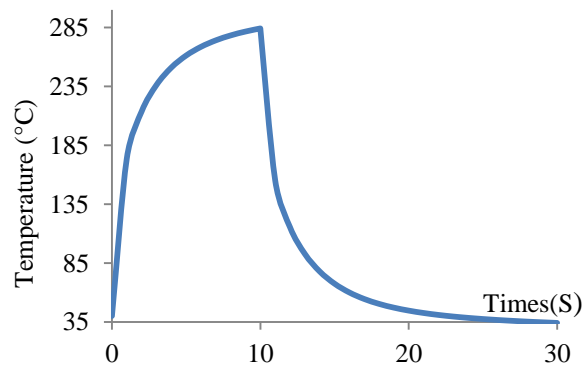

Fig5. The temperature at node 50147 versus time.

These problems have been resolved using finite element analysis to evaluate the effectiveness of various designs. This technique is accepted for the

design and development of geometrically complex components such as cylinder heads in a shorter period and with the least cost. Cylinder heads are complex

and challenging components of engines, for which the finite element analysis plays a critical role in optimization [18]. TMF analysis of each component needs the cyclic stress-strain distribution. Diesel engines hot components hold complex geometry and loading, and the applying analytical method for the detection of stress-strain distribution in them is impossible. Many researchers have used finite element method to obtain stress-strain distribution in of geometrically complex components [37]. Nowadays, simulation techniques are substitute to validation tests so as to decrease the cost and time of production [8]. Cylinder heads examined in this study are shown in Figure 3.

Cylinder heads have three valve ports, each with an embedded valve seat; two valve guides; and four bolt holes used to secure the cylinder heads to the engine blocks. Cylinder heads are made of aluminum alloy (A356.0). The two valve guides are made of steel, with a Young's modulus of 106 GPa and a Poisson's ratio of 0.35. The valve guides fit tightly into two of the cylinder heads valve ports and their behavior is presumed elastic. The three valve seats are made of steel, with a Young's modulus of 200 GPa and a Poisson's ratio of 0.3. The valve seats are press-fit into the cylinder head valve ports. This is accomplished by defining radial constraint equations [38].

The model consists of 65580 nodes and approximately 80000 degrees of freedom. Cylinder heads loading was done in two phases involving thermal analysis and mechanical analysis. The values of f , n , A and Q_{∞} were extracted from the experimental results of A356.0 from source [14] and they were entered into the Abaqus software. There are several methods to insert the values of C and γ into Abaqus software that one of them is entering yield stress at plastic strain using tensile test result [38]. The yield stress at plastic strain was extracted from tensile test result and entered into the Abaqus software.

Results and Discussion

4.1 Thermal Analysis

Thermal stresses in the cylinder heads are the dominant stresses, leading to low-cycle fatigue in the cylinder heads. Low-cycle fatigue of cylinder heads is caused by repeated start-up and shut-down cycle of the engine [12, 15, 16, 24]. The main part of cylinder heads stresses is the result of the thermal loading and the rest is caused by the combustion pressure and mechanical constraints (Figure 1)[12, 18]. Therefore,

thermal loading is the most important loading in the thermo-mechanical analysis of cylinder heads.

Knowing the precise distribution of temperature in the cylinder heads increases the accuracy of thermal analysis [12]. Accurate prediction of the temperature of the engine is very crucial and increases the precision of the FEA results [24]. As the accuracy of thermal analysis increases the accuracy of mechanical analysis and fatigue life estimation rises [15, 16]. The combustion pressure causes high-cycle fatigue in cylinder heads [2, 5]. Many researchers believe that the combustion pressure has secondary effect in the TMF of cylinder heads [13, 15, 16]. In finite element simulation the valves bridge, where the greatest thermal concentration exists, is subjected to thermal loading ranging from a minimum of 35°C to a maximum of 300°C [9]. The temperature distribution when the cylinder heads are heated to its peak value is shown in Figure 4.

Thermal loading has a considerable effect on the fatigue life and the temperature field identifies critical regions [8]. Crack initiation is due to the changes in the temperature field [7].

Plastic deformation and creep are observed under such conditions. The two-layer viscoplasticity model is ideally suited to examining the response of materials in these conditions [5, 9, 14, 32]. The cyclic thermal loads are obtained by performing an independent thermal analysis. In this analysis three thermal cycles are applied to obtain a steady-state thermal cycle. Each thermal cycle involves two steps: heating the cylinder heads to the maximum operating temperature and cooling it to the minimum operating temperature using the *CFLUX and *FILM options. The nodal temperatures for the last two steps (one thermal cycle) are assumed to be a steady-state solution and results are stored for use in the subsequent thermal-mechanical analysis [9]. The temperature in this region (node 50417) is shown in Figure 5 as a function of time for a steady-state cycle, representing a cycle of turning the engine on and off.

The lower temperature of the flame and the gradient temperature of the parts of cylinder heads, the less thermal stress. Thus, low-cycle fatigue life of the cylinder heads which is mainly affected by thermal fatigue will increase [21].

4.2 Mechanical analysis

Mechanical analysis was carried out in two stages. In the first stage the three valve seats are press-fit into the corresponding cylinder heads valve ports. A static analysis procedure is used for this purpose. The maximum principal stress distribution is depicted in

Figure 6 proving the stress in the valves bridge is tensile.

Figure 7 demonstrates vectors of the maximum principal stress at this stage in the valves bridge. As the figure represents the maximum principal stress in the valves bridge is tensile.

The cyclic thermal loads are applied in the second analysis step. It is assumed that the cylinder heads are securely fixed to the engine blocks through the four bolt holes, so the nodes along the base of the four bolt holes are secured in all directions during the entire simulation [9]. In the second stage the thermal cycle loads were applied so that the material behavior reaches steady state. Von-Mises stress distribution at the end of the second stage is shown in Figure 8. The maximum stress, the same as maximum temperature, occurred in the valves bridge. As shown in Figure 9 some regions of the cylinder heads entered into yield zone.

As mentioned in the sources [1, 5, 13, 18] these regions are where fatigue cracks initiate. These regions are also located in the valves bridge. Based on the sources [3, 24], the results of loading in yield surface and ultimate strength is initiation and propagation of fatigue cracks in less than 10,000 cycles.

Equivalent plastic strain distribution is depicted in Figure 10. As stated in sources [4, 22] the initiation of fatigue cracks in cylinder heads occurs where stress is tensile for the sake of assembly loads and plastic strain happens because of thermo-mechanical loads. This region is also located in the valves bridge. Based on the source [5], the first fatigue cracks can be seen at the hottest spot of cylinder heads (Figure 4). The review of Figures 4 and 6 to 10 reveals that a result of finite element analysis is corresponded with experimental tests. Cracked cylinder heads in experimental tests are shown in Figures 11 and 12.

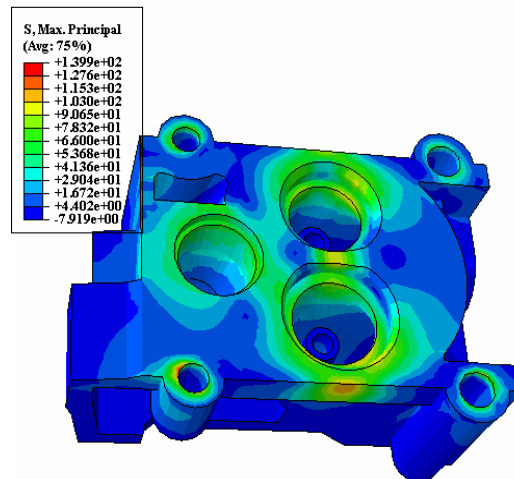

Fig6. The maximum principal stress distribution in the first stage of mechanical loading.

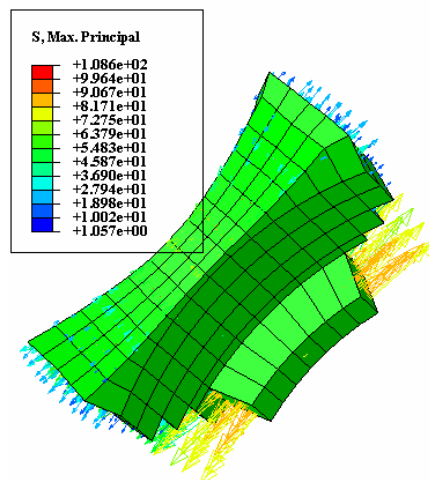

Fig7. The maximum principal stress vectors in the valve bridges due to the assembly loads.

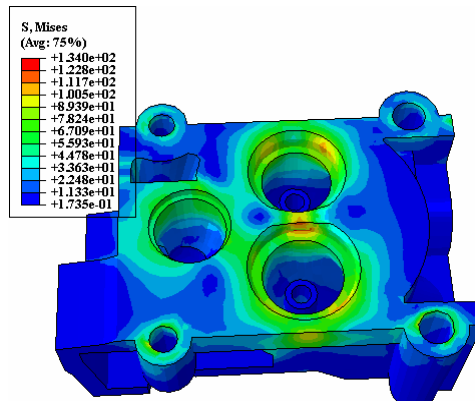

Fig8. The Von-Mises stress distribution at the end of the second stage of mechanical loading.

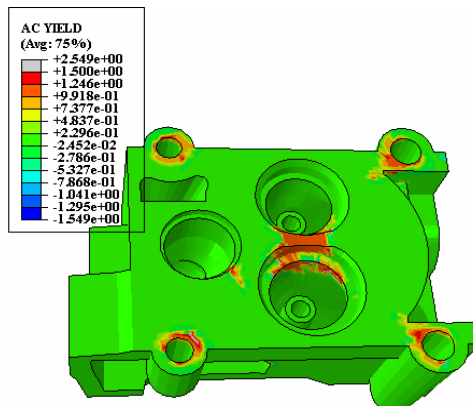

Fig9. The regions of cylinder head entered into yield zone.

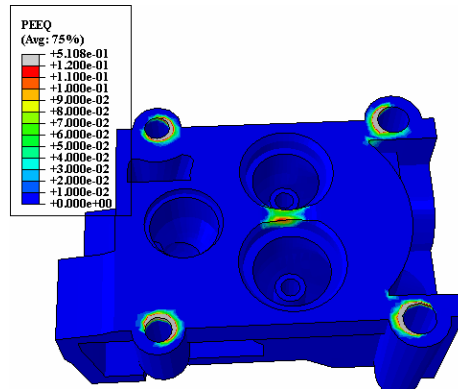

Fig10. The equivalent plastic strain distribution.



Fig11. The cracked diesel engine cylinder head [19].

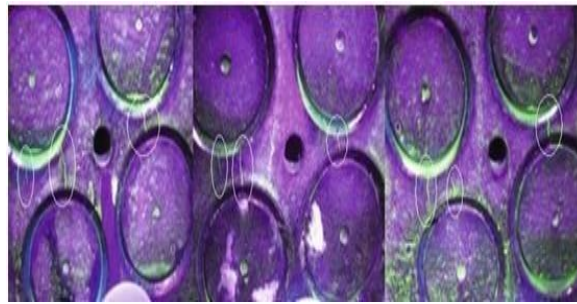

Fig12. The cracked diesel engine cylinder head [11].

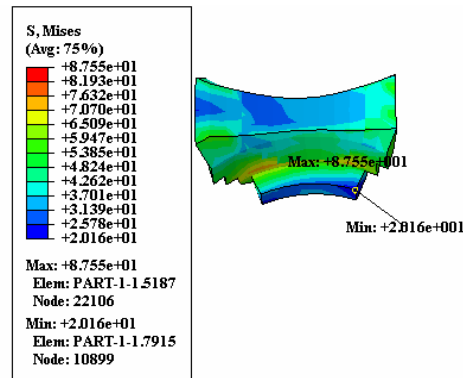

Fig13. The Von-Mises stress distribution in the valve bridge (in tenth second).

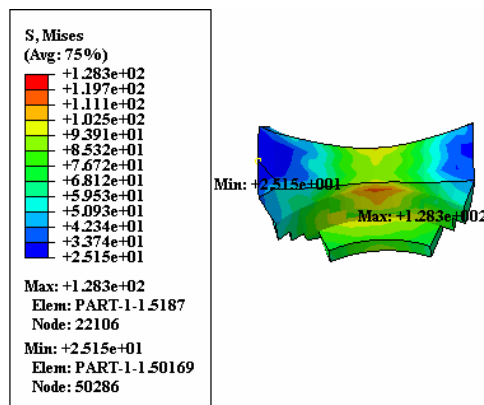

Fig14. The Von-Mises stress distribution in the valve bridge (in tenth second).

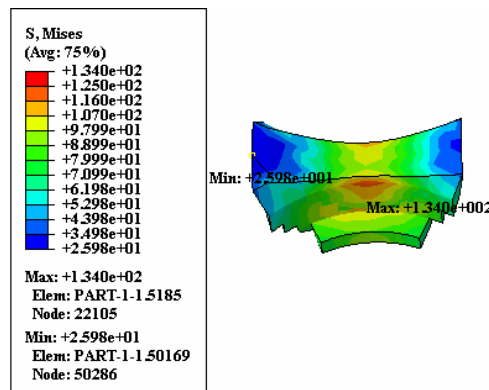

Fig15. The Von-Mises stress distribution in the valve bridge (in thirtieth second).

The valve bridge is a crucial region[3, 4, 11, 18, 19]. The changes of Von-mises stress in this area are shown in Figures 13 to 15. The Figures also include the locations of minimum and maximum Von-mises stresses. As presented in Figures 13 to 15, the valve bridge is under high stress fluctuations. The location of cracks in cylinder heads is in the valves bridge. This region endures maximum stress due to the less thickness of material and high temperature caused by lack of proper cooling. Ergo, the cylinder heads will crack. Stress functions inversely to the thickness of the material. Namely, the thinnest locations withstand the highest stress. If the valves bridge becomes wider, it will be cooled better and consequently temperature gradient and thermal stress will reduce. Thus, fatigue life of cylinder heads increases [3].

The finite element model (FEM) predicts a large compressive stress field in the valves bridge as shown in Figure 8. Thermal expansion of hot spots in cylinder heads are constrained by cool regions which

have less thermal expansion. As a result, the compressive stress is created in the valves bridge which corresponds to the results of the source [18]. Figure 16 displays diagram of normal stresses (S11), plastic stress (PS11) and viscous stress (VS11) in the X direction for point 1 of element 50152. These elements are in the valves bridge.

The engines experience maximum temperature in tenth second of running (Figure 5). Stresses are compressive because of the thermal loading and combustion pressure at the moment (Figure 16). The thermal loading and mechanical constraints generate a compressive stress field, which may drive to compressive yield surface (Figure 9). As the engine shuts off and its temperature gradually decreases to the room temperature, the stress is tensile for the sake of assembly loads (Figure 16). The yielding regions of the cylinder heads cannot return to the primary condition. Hence, tensile stress is created in this area and elastic regions.

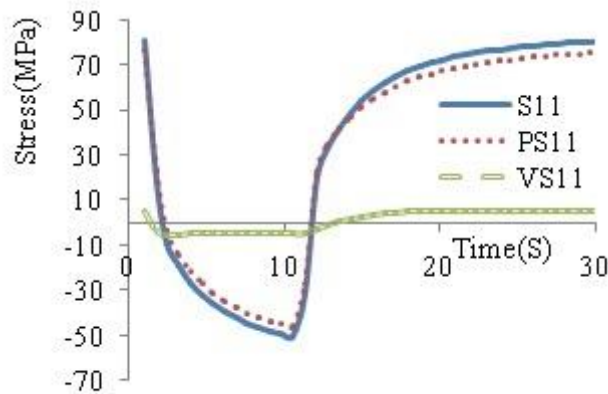

Fig16. The normal, plastic and viscous stresses in the X direction for point 1 of element 50152 versus time.

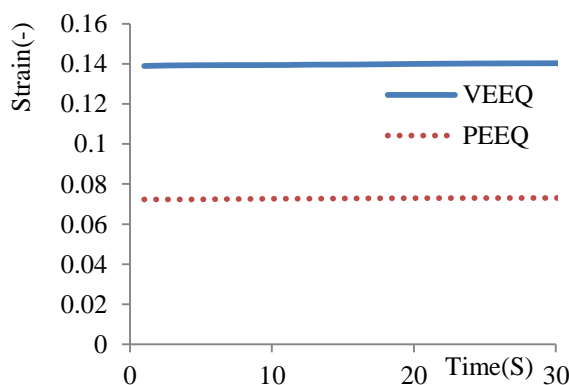

Fig17. The equivalent plastic strain and equivalent viscous strain for point 1 of element 50152 versus time.

The stress field for the yield surfaces is compressive at high temperature and turns into tensile stress at low temperature; it is correspondence to the results of sources [4, 13, 22]. The valves bridge is under the cyclic tensile and compressive stress which corresponds to the results of sources [10]. According to the source [13], changes in cyclic compressive and tensile stresses cause cracks in cylinder heads. As noted in the source [22], after a few cycles the aluminum alloy ages and drastically loses its strength. Aged material is unable to resist high tensile stresses, then cracks in the cylinder heads will appear. As the Figure 16 describes viscous stress is low and the normal and plastic stresses are almost identical.

Diagrams of equivalent plastic strain and the equivalent viscous for point 1 of element 50152 are displayed in Figure 17. As the figure describes viscous strain is more than the plastic strain and its amount is not negligible. Thus, viscous properties must be considered in the thermo-mechanical analysis of cylinder heads.

5. Conclusion

In this study coupled thermo-mechanical analysis of diesel engines cylinder heads was studied. A two-layer viscoplasticity model was used for this purpose. This model makes the cyclic stress-strain behavior of the material predictable. Finite element analysis provides accurate and reliable prediction of temperature and fatigue results in the design of diesel engines cylinder heads. Result of FEA showed stresses inside the combustion chamber exceed the elastic limit. The results of the thermo-mechanical analysis indicated that the maximum temperature and stress occurred in the valves bridge. The results of the finite element analysis correspond with the experimental tests, carried out by researchers, and illustrated the cylinder heads cracked in this region. Finite element analysis results proved the stresses in the valves bridge is compressive when the engine is running and becomes tensile when the engine shuts off. The valves bridge was under the cyclic tensile and compressive stress, in which the plastic strain happens. Low-cycle fatigue always occurs in this region and fatigue cracks appear after a few cycles. Changes in cyclic compressive and tensile stresses causes cracks in cylinder heads. In order to prevent cylinder heads cracking it is recommended to modify cooling system of engines and thickness and geometry of material in crucial parts. Since the thinner regions endure high stress, cylinder heads crack in these regions. TBC might also be used in the regions which not only boost the engine performance, but also increase the fatigue life of cylinder heads.

Since they reduce thermal stress, fatigue life of the cylinder heads grows. Materials of high thermal conductivity can be used in the regions. Materials of high thermal conductivity decrease the maximum temperature in this region, leading to the increase in fatigue life of the cylinder heads. Cutting the valves bridge approaches the region to cylinder heads cooling jackets. Consequently, the temperature in the region decreases and fatigue life of the cylinder heads increases. The thermo-mechanical analysis of the cylinder heads can determine the optimum cutting to achieve the desired lifetime. It is worth noticing that the amount of the cylinder heads material which is cut is small. However, the increase in volume that is created in the combustion chamber can be compensated by cutting the liner to avoid change in engine compression ratio. Viscous strain was more than the plastic strain and it is significant. Thus, viscous properties must be considered in the thermo-mechanical analysis of cylinder heads. Temperature was effective on stress-strain curves and thermo-mechanical analysis of the cylinder heads must be coupled.

References

- [1]. Azadi M., Mafi A., Roozban M., Moghaddam F., Failure analysis of a cracked gasoline engine cylinder head, *Journal of Failure Analysis and Prevention*, 12, 2012, pp. 286-294.
- [2]. Azadi M., Winter G., Farrahi G.H., Eichlseder W., Design of cylinder head and block in international combustion engines based on fatigue strength of materials, 8th International Conference on Internal Combustion Engines and Oil, Tehran, Iran, 2012.
- [3]. Gocmez T., Pishinger S., A contribution to the understanding of thermo-mechanical fatigue sensitivities in combustion engine cylinder heads, *Journal of Automobile Engineering*, 225, 2011, pp. 461-477.
- [4]. Li J., Wang P., Cui X., Li K., Yi R., Gray Cast Iron Cylinder Head Thermal Mechanical Fatigue Analysis, Proceedings of the FISITA 2012 World Automotive Congress Lecture Notes in Electrical Engineering, Berlin, Germany, 2013, 189, pp. 243-257.
- [5]. Metzger M., Leidenfrost M., Werner E., Riedel H., Seifert T., Lifetime Prediction of EN-GJV 450 Cast Iron Cylinder Heads under Combined Thermo-mechanical and High Fatigue Loading, SAE International Paper No.2014-01-9047, 2014.
- [6]. Su X., Zubeck M., Lasecki J., Engler-Pinto Jr C.C., Tang C., Sehitoglu H., Allison J., Thermal fatigue analysis of cast aluminum cylinder heads, SAE International Paper No.2002-01-0657, 2002.
- [7]. Thalmer S., Thiele J., Fishersworing-Bunk A., Ehart R., Guillou M., Cylinder heads for high power gasoline engines-thermo-mechanical fatigue life prediction, SAE International Paper No.2006-01-0655, 2006.
- [8]. Trampert S., Gocmez T., Pisinger S., Thermo-mechanical fatigue life prediction of cylinder head in combustion engines, *Journal of Engineering for Gas Turbines and Power*, 130, 2008, pp. 1-10.
- [9]. Zahedi F., Azadi M., Low-cycle fatigue life analysis of magnesium alloy diesel engine cylinder head, 20th Annual International Conference on Mechanical Engineering, Shiraz, Iran, 2012, Paper No. ISME2012-2063.
- [10]. Xuyang G., Cheng Y., Zhang Z., Thermo-mechanical fatigue life prediction of heavy duty diesel engine cylinder head, ASME International Mechanical Engineering Congress and Exposition, California, U.S.A 2013.
- [11]. Takahashi T., Sasaki K., Low-cycle fatigue of aluminum alloy cylinder head in consideration of changing metrology microstructure, *Journal of Procedia Engineering*, 2, 2010, pp. 767-776.
- [12]. Mirsalim S.M., Chamani H.R., Rezaloo Y., Keshavarz M., Jafarabadi M., Analysis of Cracked Cylinder Head of Diesel Engine due to Fatigue and Improvement its Design, 6th International Conference on Internal Combustion Engines, Tehran, Iran, 2009.
- [13]. Takahashi T.I., Nagayoshi T., Kumano M., Sasaki K., Thermal plastic-elastic creep analysis of engine cylinder head, SAE International Paper No.2002-01-585, 2002.
- [14]. Farrahi G.H., Ghodrati M., Azadi M., Rezvani Rad M., Stress-strain time-dependent behavior of A356.0 aluminum alloy subject to cyclic thermal and mechanical loading, *Journal of Mech Time-Depend Mater*, 18, 2014, pp. 475-491.
- [15]. Thomas J.J., Vergner L., Bignonnet A., Borret S.M., Thermo-mechanical design in the automotive industry, SAE International Paper No.2002-01-0659, 2002.
- [16]. Thomas J.J., Vergner L., Bignonnet A., Charkaluk E., Thermo-mechanical design in the automotive industry, *Journal of Fatigue and Fracture of Engineering Material and Structure*, 27, 2004, pp. 887-895.
- [17]. Remy L., Petit J., Temperature-Fatigue interaction, Elsevier, Paris, France, 2001.
- [18]. Shojaefard M.H., Ghaffarpour M.R., Nourpour A.R., Alizadenia S., Thermo-mechanical Analysis of an Engine Cylinder Head, *Journal of Automobile Engineering*, 220, 2006, pp.627-636.
- [19]. Ziehler F., Langmayr F., Jelatancev A., Wieser K., Thermal mechanical fatigue simulation of cast iron cylinder heads, SAE International Paper No.2005-01-0796, 2005.
- [20]. Challen B., Baranescu R., Diesel Engine Reference Book, 2nd Edition, Butterworth-Heinemann, Oxford, England, 1999.
- [21]. Chamani H.R., Sattarifar I., Mohammadi Aghdam M., Study of effect combustion gases and cooling thermal boundary conditions on temperature distribution of a heavy diesel engine cylinder head, *Journal of engine research*, 17, 2009, pp. 71-81.
- [22]. Koch F., Massan F., Deuster U., Loeprecht M., Marckward H., Low-cycle fatigue of aluminum cylinder heads-Calculation and measurement of stain under fired operation, SAE International Paper No.1999-01-0645, 1999.

- [23]. Venkateswaran N., Vinobakrishnan R., Balamurugan V., Thermo-mechanical Analysis of the Cylinder Block with the Liner of AFV Diesel Engine, SAE International Paper No.2011-28-0118, 2011.
- [24]. Ghasemi A., Cylinder Head High/Low Cycle Fatigue CAE Analysis, SAE International Paper No.2012-01-1999, 2012.
- [25]. Rahman M.M., Arffin A.K., Abdullah S., Noor M.M., Baker R.A., Maleque M.A., Fatigue life prediction of cylinder head for two stroke linear engine using stress-life approach, Journal of Applied Science, 8, 2008, pp. 3316-3327.
- [26]. Bialas M., Finite element analysis of stress distribution in thermal barrier coating, Journal of surface and coating, 202, 2008, pp. 6002-6010.
- [27]. Azadi M., Balo M., Farrahi G.H., Mirsalim, S.M., A review of thermal barrier effects on diesel engine performance and components lifetime, International Journal of Automotive Engineering, 3, 2013, pp. 305-317.
- [28]. Moridi A., Azadi M., Farrahi, G.H., Numerical simulation of thermal barrier coating system under thermo-mechanical lading, Word congress on engineering, London, England, 2011.
- [29]. Moridi A., Azadi M., Farrahi, G.H., Coating thickness and roughness effect on stress distribution of A356.0 under thermo-mechanical lading, Journal of Procedia Engineering, 10, 2011, pp. 1372-1378.
- [30]. Moridi A., Azadi M., Farrahi, G.H., Thermo-mechanical stress analysis of thermal barrier coating system considering thickness and roughness effects, Journal of Surface and Coating, 243, 2014, pp. 91-99.
- [31]. Kichenin J., Dang van K., Boytard K., Finite-element simulation of a new two-dissipative mechanisms model for bulk medium-density polyethylene, Journal of Material Science, 32,1996, pp. 1653-1661.
- [32]. Deshpande A., Leen S.B., Hyde T.H., Experimental and numerical characterization of the cyclic thermo-mechanical behavior of a high temperature forming tool alloy, ASME Journal of Manufacturing Science and Engineering, 132, 2010, pp.1-12.
- [33]. Lemaitre J., Chaboche J., Mechanics of Solid Materials, Cambridge University Press, Cambridge, 1990.
- [34]. Chaboche J. L., Time-independent constitutive theories for cyclic plasticity. International Journal of Plasticity 2, 2, 1986, pp. 149–188.
- [35]. Chaboche J. L., A review of some plasticity and viscoplasticity constitutive theories. International Journal of Plasticity 24, 2008, pp. 1642–1693.
- [36]. Angeloni M., Fatigue life evaluation of A356 aluminium alloy used for engine cylinder head, Ph.D Thesis, University of Sao Palu, Brazil, 2011.
- [37]. Sun G.Q., Shang D.G., Prediction Of Fatigue Lifetime Under multiracial Cyclic Loading Using Finite Element Analysis, Journal of Material and Design, 31, 2010, pp. 126-133.
- [38]. ABAQUS/CAE(v6.10-1), User' s Manual, 2010.